

商業數量方法

Summer 2026

政治大學統計系余清祥
2026年6月29日及30日
第7~10章：估計與檢定
<http://csyue.nccu.edu.tw>



Chapter 7 - Sampling and Sampling Distributions

7.1 – The Electronics Associates Sampling Problem

7.2 – **Selecting a Sample**

7.3 – Point Estimation

7.4 – **Introduction to Sampling Distributions**

7.5 – **Sampling Distribution of \bar{x}**

7.6 – Sampling Distribution of \bar{p}

7.7 – Properties of Point Estimators

7.8 – **Other Sampling Methods**

7.9 – Big Data and Standard Errors of Sampling Distributions

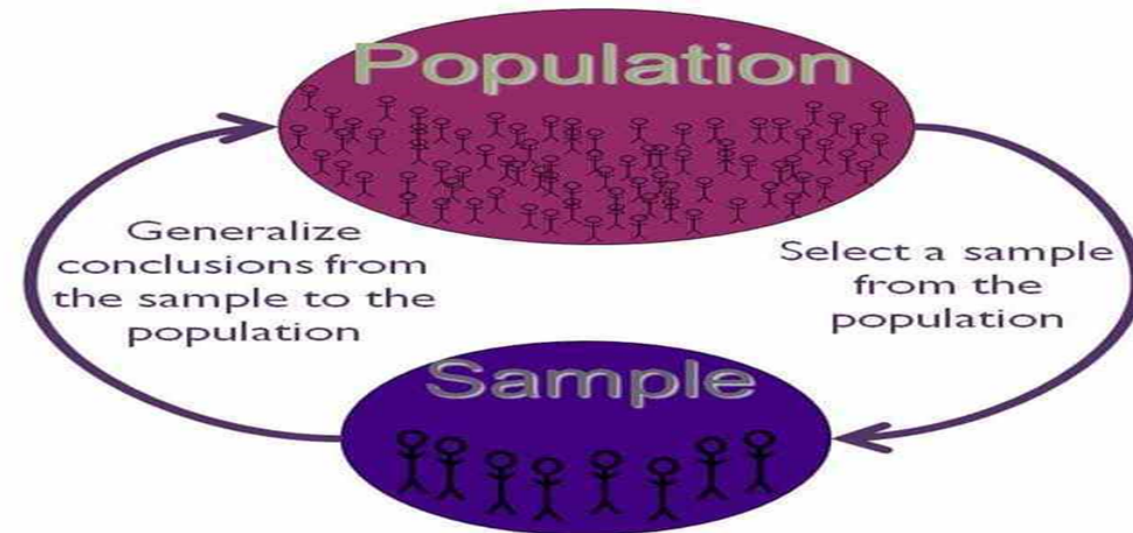

https://encrypted-tbn0.gstatic.com/images?q=tbn:ANd9GcTtOH11e3m9uwwqpullIyeBRkSxUnu4_Tw7JA&usqp=CAU

對樣本的要求

- 因為我們將從樣本推測出母體的原貌，抽出的部分必須能反映全體的特性，也就是說樣本需能代表母體。

→ 樣本代表性!!!

→ 最忌諱「瞎子摸象」



大數據層級的資料蒐集

- 產業界（如人力資源）大多仍以傳統問卷形式蒐集資料，很容易造成流失及扭曲。
 - 冷備份 vs. 熱備份（高成本！）
 - 次級資料 vs. 原始資料（自由心證！）
 - 樣本 vs. 母體（抽樣偏差！）
- 註：誘導性文字（「額外資訊」）、敏感性議題（「收入」）等也會有品質問題。

目標母體與實際母體

- 無論是實驗設計或是觀察研究，抽取樣本需要謹慎規劃，確保目標與實際兩者一致。

→ 例如：藉由民意調查獲取台北市長的施政滿意度，先確定受訪者為台北市民，可先詢問受訪者是否為「居住」在台北市的市民。

註：「戶籍人口」 vs. 「常住人口」

表3 匹茲堡睡眠品質量表⁽¹³⁾

請針對您過去一個月內夜間睡眠情形之大概狀況，回答最適合您情況的答案

1. 過去一個月來，你通常何時上床？ _____ 時 _____ 分
2. 過去一個月來，你通常多久才能入睡？ _____ 分鐘
3. 過去一個月來，你早上通常何時起來？ _____ 時 _____ 分
4. 過去一個月來，你實際每晚可以入睡幾小時？ _____ 時 _____ 分

以下5、6、7、8題計分方式如下

0分：從來沒有 1分：一週少於一次 2分：一週兩次 3分：一週超過三次以上

5. 過去一個月來，您睡眠問題被以下情況所干擾的次數如何？

- | | |
|----------------------|--------------------|
| (1) 無法在30分鐘內入睡 _____ | (2) 半夜或凌晨便清醒 _____ |
| (3) 必須起來上廁所 _____ | (4) 覺得呼吸不順暢 _____ |
| (5) 大聲打鼾或咳嗽 _____ | (6) 會覺得冷 _____ |
| (7) 覺得躁熱 _____ | (8) 作惡夢 _____ |
| (9) 身上有疼痛 _____ | (10) 其他(請說明) _____ |

由受訪者
填答可能
衍生的問
題？

6.(A)請問您喝紹興酒或陳紹，那一種為主？紹興酒為主 陳紹為主 紹興/陳紹一樣 不喝

(B)您對下列酒的整體印象是：

		紹興/陳紹				紅葡萄酒				白葡萄酒				啤酒				白蘭地/威士忌				高粱酒/白酒			
		非	贊	沒	反	非	贊	沒	反	非	贊	沒	反	非	贊	沒	反	非	贊	沒	反	非	贊	沒	反
		常	意	常	對	常	意	常	對	常	意	常	對	常	意	常	對	常	意	常	對	常	意	常	對
		贊	成	見	對	贊	成	見	對	贊	成	見	對	贊	成	見	對	贊	成	見	對	贊	成	見	對
健	康	<input type="checkbox"/>	<input type="checkbox"/>	<input type="checkbox"/>	<input type="checkbox"/>	<input type="checkbox"/>	<input type="checkbox"/>	<input type="checkbox"/>	<input type="checkbox"/>	<input type="checkbox"/>	<input type="checkbox"/>	<input type="checkbox"/>	<input type="checkbox"/>	<input type="checkbox"/>	<input type="checkbox"/>	<input type="checkbox"/>	<input type="checkbox"/>	<input type="checkbox"/>	<input type="checkbox"/>	<input type="checkbox"/>	<input type="checkbox"/>	<input type="checkbox"/>	<input type="checkbox"/>	<input type="checkbox"/>	<input type="checkbox"/>
浪	漫	<input type="checkbox"/>	<input type="checkbox"/>	<input type="checkbox"/>	<input type="checkbox"/>	<input type="checkbox"/>	<input type="checkbox"/>	<input type="checkbox"/>	<input type="checkbox"/>	<input type="checkbox"/>	<input type="checkbox"/>	<input type="checkbox"/>	<input type="checkbox"/>	<input type="checkbox"/>	<input type="checkbox"/>	<input type="checkbox"/>	<input type="checkbox"/>	<input type="checkbox"/>	<input type="checkbox"/>	<input type="checkbox"/>	<input type="checkbox"/>	<input type="checkbox"/>	<input type="checkbox"/>	<input type="checkbox"/>	<input type="checkbox"/>
休	閒	<input type="checkbox"/>	<input type="checkbox"/>	<input type="checkbox"/>	<input type="checkbox"/>	<input type="checkbox"/>	<input type="checkbox"/>	<input type="checkbox"/>	<input type="checkbox"/>	<input type="checkbox"/>	<input type="checkbox"/>	<input type="checkbox"/>	<input type="checkbox"/>	<input type="checkbox"/>	<input type="checkbox"/>	<input type="checkbox"/>	<input type="checkbox"/>	<input type="checkbox"/>	<input type="checkbox"/>	<input type="checkbox"/>	<input type="checkbox"/>	<input type="checkbox"/>	<input type="checkbox"/>	<input type="checkbox"/>	<input type="checkbox"/>
高	貴	<input type="checkbox"/>	<input type="checkbox"/>	<input type="checkbox"/>	<input type="checkbox"/>	<input type="checkbox"/>	<input type="checkbox"/>	<input type="checkbox"/>	<input type="checkbox"/>	<input type="checkbox"/>	<input type="checkbox"/>	<input type="checkbox"/>	<input type="checkbox"/>	<input type="checkbox"/>	<input type="checkbox"/>	<input type="checkbox"/>	<input type="checkbox"/>	<input type="checkbox"/>	<input type="checkbox"/>	<input type="checkbox"/>	<input type="checkbox"/>	<input type="checkbox"/>	<input type="checkbox"/>	<input type="checkbox"/>	<input type="checkbox"/>
活	力	<input type="checkbox"/>	<input type="checkbox"/>	<input type="checkbox"/>	<input type="checkbox"/>	<input type="checkbox"/>	<input type="checkbox"/>	<input type="checkbox"/>	<input type="checkbox"/>	<input type="checkbox"/>	<input type="checkbox"/>	<input type="checkbox"/>	<input type="checkbox"/>	<input type="checkbox"/>	<input type="checkbox"/>	<input type="checkbox"/>	<input type="checkbox"/>	<input type="checkbox"/>	<input type="checkbox"/>	<input type="checkbox"/>	<input type="checkbox"/>	<input type="checkbox"/>	<input type="checkbox"/>	<input type="checkbox"/>	<input type="checkbox"/>
青	春	<input type="checkbox"/>	<input type="checkbox"/>	<input type="checkbox"/>	<input type="checkbox"/>	<input type="checkbox"/>	<input type="checkbox"/>	<input type="checkbox"/>	<input type="checkbox"/>	<input type="checkbox"/>	<input type="checkbox"/>	<input type="checkbox"/>	<input type="checkbox"/>	<input type="checkbox"/>	<input type="checkbox"/>	<input type="checkbox"/>	<input type="checkbox"/>	<input type="checkbox"/>	<input type="checkbox"/>	<input type="checkbox"/>	<input type="checkbox"/>	<input type="checkbox"/>	<input type="checkbox"/>	<input type="checkbox"/>	<input type="checkbox"/>
豪	爽	<input type="checkbox"/>	<input type="checkbox"/>	<input type="checkbox"/>	<input type="checkbox"/>	<input type="checkbox"/>	<input type="checkbox"/>	<input type="checkbox"/>	<input type="checkbox"/>	<input type="checkbox"/>	<input type="checkbox"/>	<input type="checkbox"/>	<input type="checkbox"/>	<input type="checkbox"/>	<input type="checkbox"/>	<input type="checkbox"/>	<input type="checkbox"/>	<input type="checkbox"/>	<input type="checkbox"/>	<input type="checkbox"/>	<input type="checkbox"/>	<input type="checkbox"/>	<input type="checkbox"/>	<input type="checkbox"/>	<input type="checkbox"/>
新	潮	<input type="checkbox"/>	<input type="checkbox"/>	<input type="checkbox"/>	<input type="checkbox"/>	<input type="checkbox"/>	<input type="checkbox"/>	<input type="checkbox"/>	<input type="checkbox"/>	<input type="checkbox"/>	<input type="checkbox"/>	<input type="checkbox"/>	<input type="checkbox"/>	<input type="checkbox"/>	<input type="checkbox"/>	<input type="checkbox"/>	<input type="checkbox"/>	<input type="checkbox"/>	<input type="checkbox"/>	<input type="checkbox"/>	<input type="checkbox"/>	<input type="checkbox"/>	<input type="checkbox"/>	<input type="checkbox"/>	<input type="checkbox"/>
傳	統/古板	<input type="checkbox"/>	<input type="checkbox"/>	<input type="checkbox"/>	<input type="checkbox"/>	<input type="checkbox"/>	<input type="checkbox"/>	<input type="checkbox"/>	<input type="checkbox"/>	<input type="checkbox"/>	<input type="checkbox"/>	<input type="checkbox"/>	<input type="checkbox"/>	<input type="checkbox"/>	<input type="checkbox"/>	<input type="checkbox"/>	<input type="checkbox"/>	<input type="checkbox"/>	<input type="checkbox"/>	<input type="checkbox"/>	<input type="checkbox"/>	<input type="checkbox"/>	<input type="checkbox"/>	<input type="checkbox"/>	<input type="checkbox"/>
帥	氣	<input type="checkbox"/>	<input type="checkbox"/>	<input type="checkbox"/>	<input type="checkbox"/>	<input type="checkbox"/>	<input type="checkbox"/>	<input type="checkbox"/>	<input type="checkbox"/>	<input type="checkbox"/>	<input type="checkbox"/>	<input type="checkbox"/>	<input type="checkbox"/>	<input type="checkbox"/>	<input type="checkbox"/>	<input type="checkbox"/>	<input type="checkbox"/>	<input type="checkbox"/>	<input type="checkbox"/>	<input type="checkbox"/>	<input type="checkbox"/>	<input type="checkbox"/>	<input type="checkbox"/>	<input type="checkbox"/>	<input type="checkbox"/>
典	雅	<input type="checkbox"/>	<input type="checkbox"/>	<input type="checkbox"/>	<input type="checkbox"/>	<input type="checkbox"/>	<input type="checkbox"/>	<input type="checkbox"/>	<input type="checkbox"/>	<input type="checkbox"/>	<input type="checkbox"/>	<input type="checkbox"/>	<input type="checkbox"/>	<input type="checkbox"/>	<input type="checkbox"/>	<input type="checkbox"/>	<input type="checkbox"/>	<input type="checkbox"/>	<input type="checkbox"/>	<input type="checkbox"/>	<input type="checkbox"/>	<input type="checkbox"/>	<input type="checkbox"/>	<input type="checkbox"/>	<input type="checkbox"/>
和	諧	<input type="checkbox"/>	<input type="checkbox"/>	<input type="checkbox"/>	<input type="checkbox"/>	<input type="checkbox"/>	<input type="checkbox"/>	<input type="checkbox"/>	<input type="checkbox"/>	<input type="checkbox"/>	<input type="checkbox"/>	<input type="checkbox"/>	<input type="checkbox"/>	<input type="checkbox"/>	<input type="checkbox"/>	<input type="checkbox"/>	<input type="checkbox"/>	<input type="checkbox"/>	<input type="checkbox"/>	<input type="checkbox"/>	<input type="checkbox"/>	<input type="checkbox"/>	<input type="checkbox"/>	<input type="checkbox"/>	<input type="checkbox"/>
補	身	<input type="checkbox"/>	<input type="checkbox"/>	<input type="checkbox"/>	<input type="checkbox"/>	<input type="checkbox"/>	<input type="checkbox"/>	<input type="checkbox"/>	<input type="checkbox"/>	<input type="checkbox"/>	<input type="checkbox"/>	<input type="checkbox"/>	<input type="checkbox"/>	<input type="checkbox"/>	<input type="checkbox"/>	<input type="checkbox"/>	<input type="checkbox"/>	<input type="checkbox"/>	<input type="checkbox"/>	<input type="checkbox"/>	<input type="checkbox"/>	<input type="checkbox"/>	<input type="checkbox"/>	<input type="checkbox"/>	<input type="checkbox"/>
料	理	<input type="checkbox"/>	<input type="checkbox"/>	<input type="checkbox"/>	<input type="checkbox"/>	<input type="checkbox"/>	<input type="checkbox"/>	<input type="checkbox"/>	<input type="checkbox"/>	<input type="checkbox"/>	<input type="checkbox"/>	<input type="checkbox"/>	<input type="checkbox"/>	<input type="checkbox"/>	<input type="checkbox"/>	<input type="checkbox"/>	<input type="checkbox"/>	<input type="checkbox"/>	<input type="checkbox"/>	<input type="checkbox"/>	<input type="checkbox"/>	<input type="checkbox"/>	<input type="checkbox"/>	<input type="checkbox"/>	<input type="checkbox"/>

7.(A)您想購買紹興/陳紹，下列那些地方曾讓您買不到？(可複選)

- 沒買過
- 餐廳
- 路邊攤
- 便利商店
- 雜貨店
- KTV
- 酒廊
- PUB
- 超市
- 量販店
- 洋酒專賣店
- 去買的地方，都買到
- 其他_____

(B)上個月中您本人喝或用紹興酒/陳紹的場合為何？

	次數	百分比(飲用量/紹興/陳紹總用量)
婚喪大宴	_____	_____
KTV、酒廊、PUB	_____	_____
平常宴客	_____	_____
聚餐吃飯	_____	_____
自己小飲	_____	_____
※料理食物(作業者才填)	_____	_____
其他_____	_____	_____

8.(A)您目前的行業是：(單選)

- 軍公教
- 農林漁牧業
- 礦產及土石採取業
- 製造業
- 水電燃氣
- 營造、建築業
- 交通、運輸及倉儲業
- 金融保險不動產業
- 資訊、通信業(製造除外)
- 貿易
- 顧問、公關公司
- 文化傳播娛樂、出版業
- 餐飲業
- 家庭主婦
- 學生
- 自由業
- 服務業(商店,百貨....)
- 其他_____

(B)您的工作型態為：(單選)

- 業務人員
- 行政事務人員
- 勞務人員
- 服務職
- 知識性工作
- 家庭主婦
- 學生
- 享清福

若您對本問卷有任何建議，請寫在背面空白處。

儀器量測更為精確，但資料蒐集不易！

ersion)



清醒期 (Awake)
低電位高頻的貝它(β)波



瞋睡期 (Drowsy)
主要是阿爾發波(α)



睡眠期第一階段
主要是西塔波(θ)



睡眠期第二階段
出現睡眠紡錘波
(sleep spindle)



睡眠期第三與第四階段
慢波睡眠，逐漸出現較
多的德爾他波(δ)



REM睡眠
出現類似醒覺期的
低電位高頻的波

Sampling from a Finite Population (1 of 2)

- Finite populations are often defined by lists such as:
 - Organization membership roster
 - Credit card account numbers
 - Inventory product numbers
- A simple random sample of size n from a finite population of size N is a sample selected such that each possible sample of size n has the same probability of being selected.
- Replacing each sampled element before selecting subsequent elements is called sampling with replacement. An element can appear in the sample more than once.
- Sampling without replacement is the procedure used most often.
- In large sampling projects, computer-generated random numbers are often used to automate the sample selection process.

Sampling from a Finite Population (2 of 2)

St. Andrew's College received 900 applications for admission in the upcoming year from prospective students. The applicants were numbered, from 1 to 900, as their applications arrived. The Director of Admissions would like to select a simple random sample of 30 applicants.

Step 1: Assign a random number to each of the 900 applicants.

The random numbers generated by Excel's *RAND* function follow a uniform probability distribution between 0 and 1.

Step 2: Select the 30 applicants corresponding to the 30 smallest random numbers.

Sampling from an Infinite Population (1 of 3)

- Sometimes we want to select a sample, but find that it is not possible to obtain a list of all elements in the population.
- As a result, we cannot construct a frame for the population.
- Hence we cannot use the random number selection procedure.
- Most often this situation occurs in the case of infinite population.

Sampling from an Infinite Population (2 of 3)

- Populations are often generated by an ongoing process where there is no upper limit on the number of units that can be generated.
- Some examples of on-going processes with infinite populations are:
 - parts being manufactured on a production line
 - transactions occurring at a bank
 - telephone calls arriving at a technical help desk
 - customers entering a store

Sampling from an Infinite Population (3 of 3)

- In the case of an infinite population, we must select a random sample in order to make valid statistical inferences about the population from which the sample is taken.
- A random sample from an infinite population is a sample selected such that the following conditions are satisfied.
 - Each element selected comes from the population of interest.
 - Each element is selected independently.

Sampling Distribution of \bar{x} (1 of 10)

Process of Statistical Inference

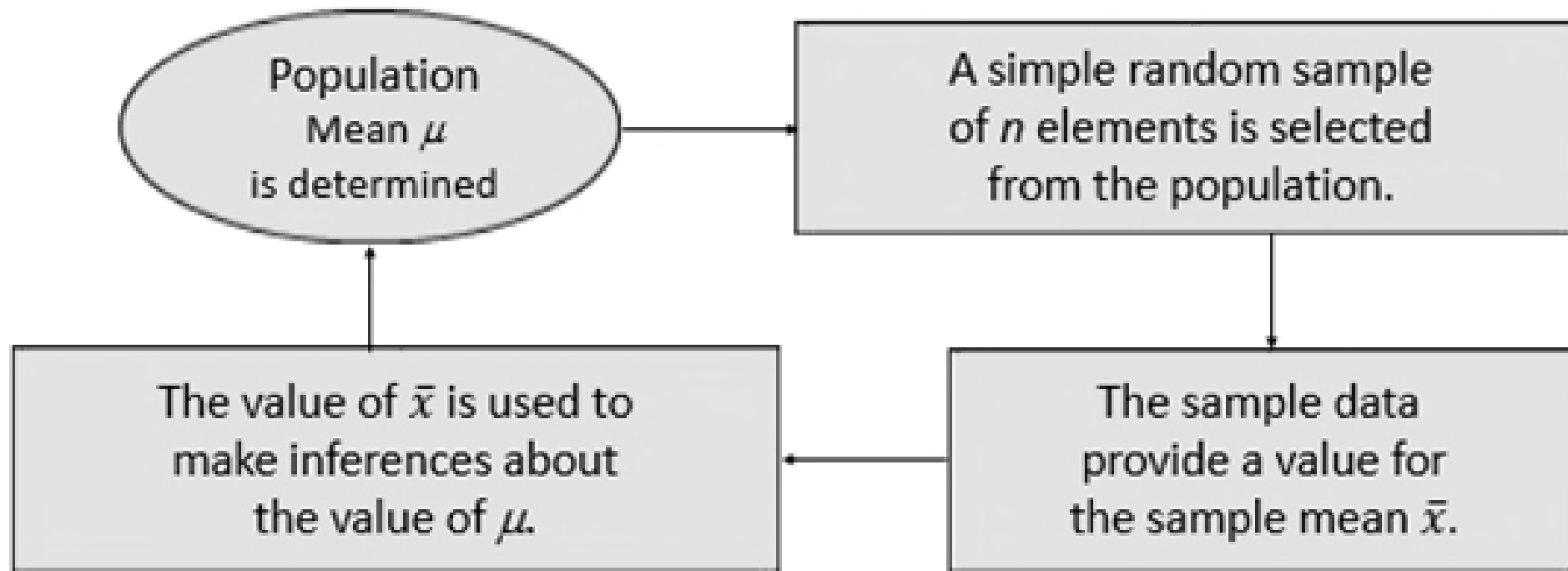

Sampling Distribution of \bar{x} (2 of 10)

- The sampling distribution of \bar{x} is the probability distribution of all possible values of the sample mean \bar{x} .
- Expected Value of \bar{x} is $E(\bar{x}) = \mu$, where μ = the population mean.
- When the expected value of the point estimator equals the population parameter, we say the point estimator is unbiased.

Sampling Distribution of \bar{x} (3 of 10)

We will use the following notation to define the standard deviation of the sampling distribution of \bar{x} :

- $\sigma_{\bar{x}}$ = the standard deviation of \bar{x}
- σ = the standard deviation of the population
- n = the sample size
- N = the population size

Sampling Distribution of \bar{x} (4 of 10)

- The standard deviation of \bar{x} , for a finite population is $\sigma_{\bar{x}} = \sqrt{\frac{N-n}{N-1}} \left(\frac{\sigma}{\sqrt{n}} \right)$.
- The standard deviation of \bar{x} , for a finite population is $\sigma_{\bar{x}} = \frac{\sigma}{\sqrt{n}}$.
- A finite population is treated as being infinite if $n/N \leq 0.05$.
- $\sqrt{\frac{N-n}{N-1}}$ is the finite population correction factor.
- $\sigma_{\bar{x}}$ is referred to as the standard error of the mean.

Sampling Distribution of \bar{x} (5 of 10)

- When the population has a normal distribution, the sampling distribution of \bar{x} is normally distributed for any sample size.
- In most applications, the sampling distribution of \bar{x} can be approximated by a normal distribution whenever the sample is size 30 or more.
- In cases where the population is highly skewed or outliers are present, samples of size 50 may be needed.
- The sampling distribution of \bar{x} can be used to provide probability information about how close the sample mean \bar{x} is to the population mean μ .

Central Limit Theorem (中央極限定理)

When the population from which we are selecting a random sample does not have a normal distribution, the central limit theorem is helpful in identifying the shape of the sampling distribution of \bar{x} .

Central Limit Theorem

In selecting random samples of size n from a population, the sampling distribution of the sample mean \bar{x} can be approximated by a *normal distribution* as the sample size becomes large.

Central Limit Theorem

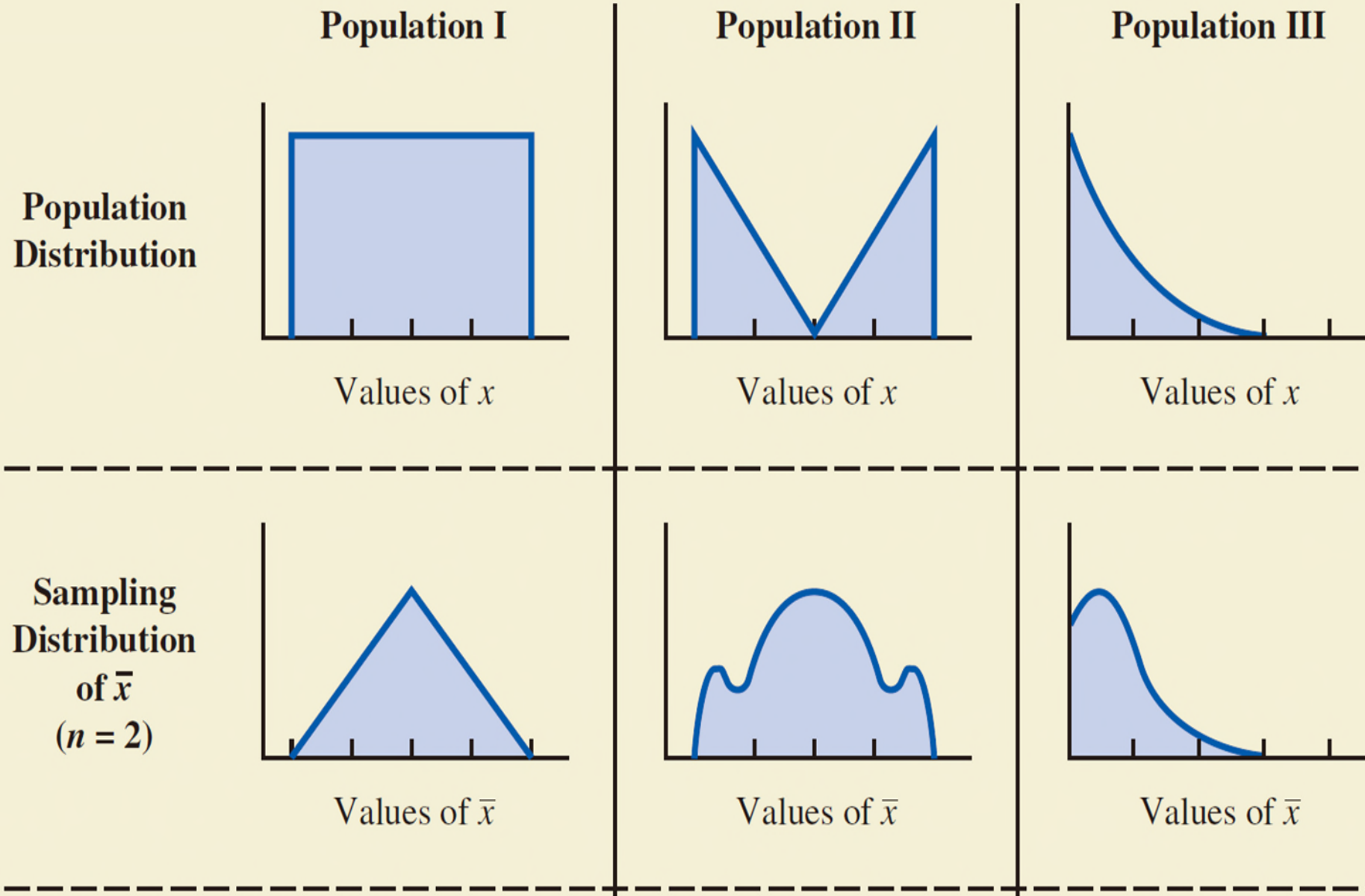

Central Limit Theorem (Conti.)

Sampling
Distribution
of \bar{x}
($n = 5$)

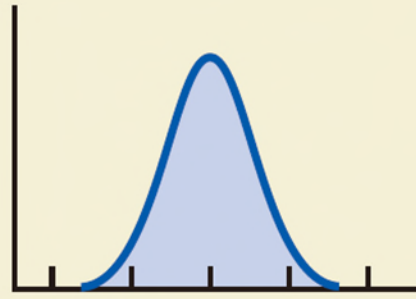

Values of \bar{x}

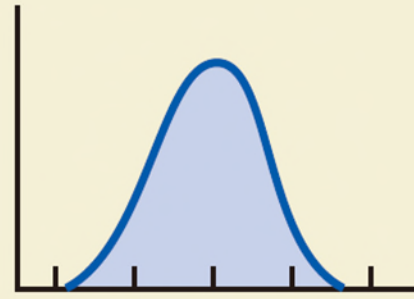

Values of \bar{x}

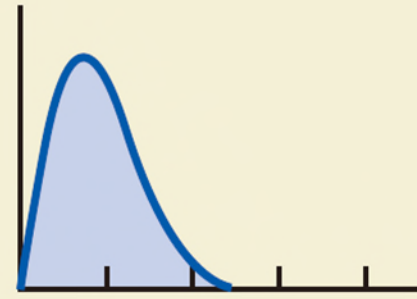

Values of \bar{x}

Sampling
Distribution
of \bar{x}
($n = 30$)

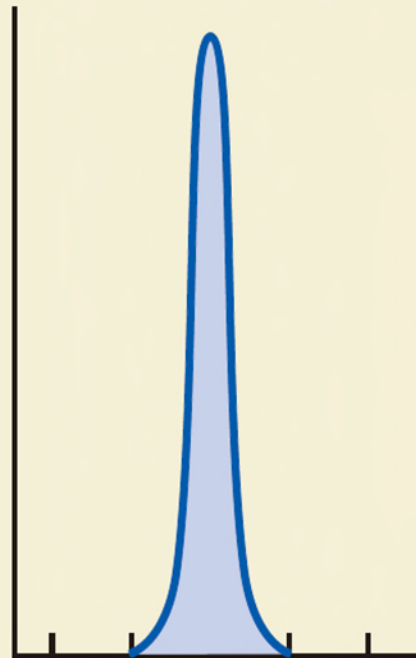

Values of \bar{x}

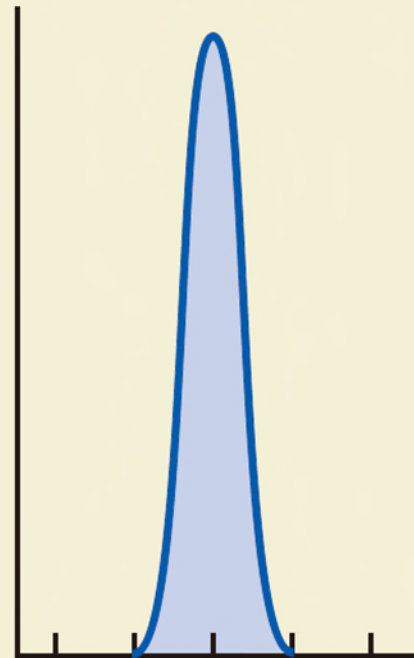

Values of \bar{x}

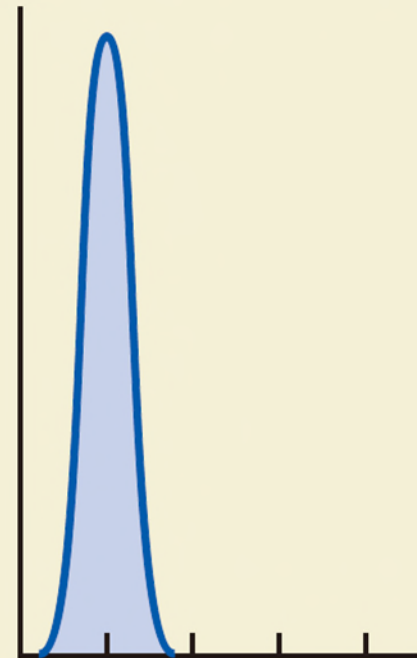

Values of \bar{x}

抽樣分配(Sampling Distribution)

$n = 1$



0.5

$n = 5$

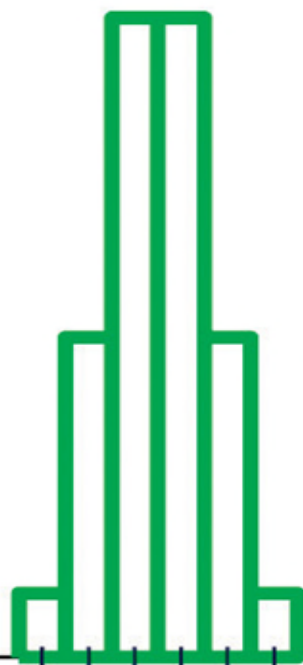

0

1

$n = 10$

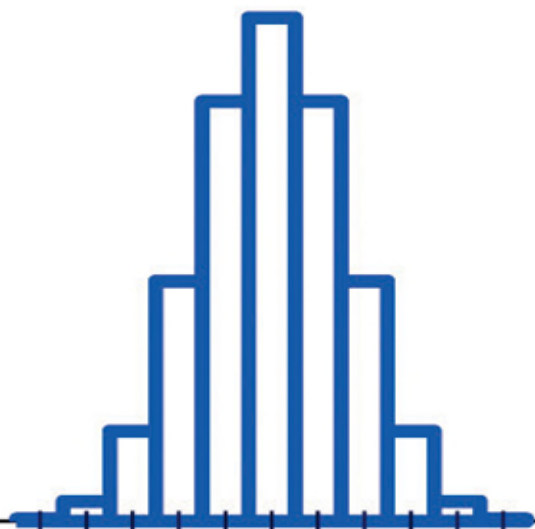

0

1

$n = 20$

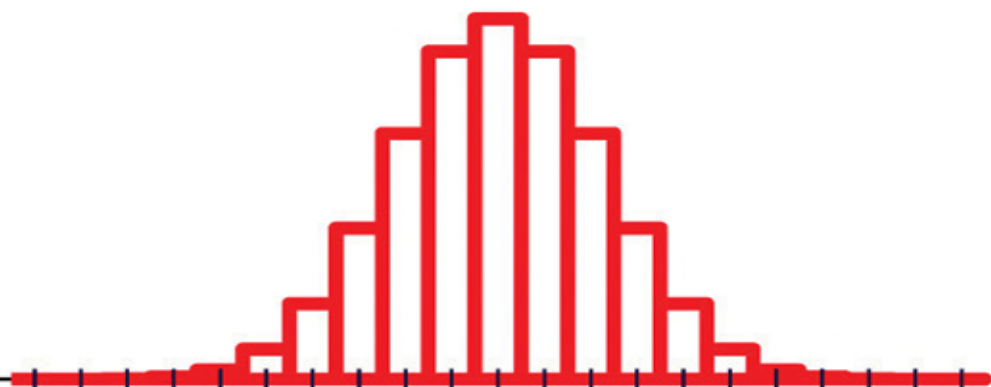

0

1

經驗法則

Regular

Irregular

Extreme

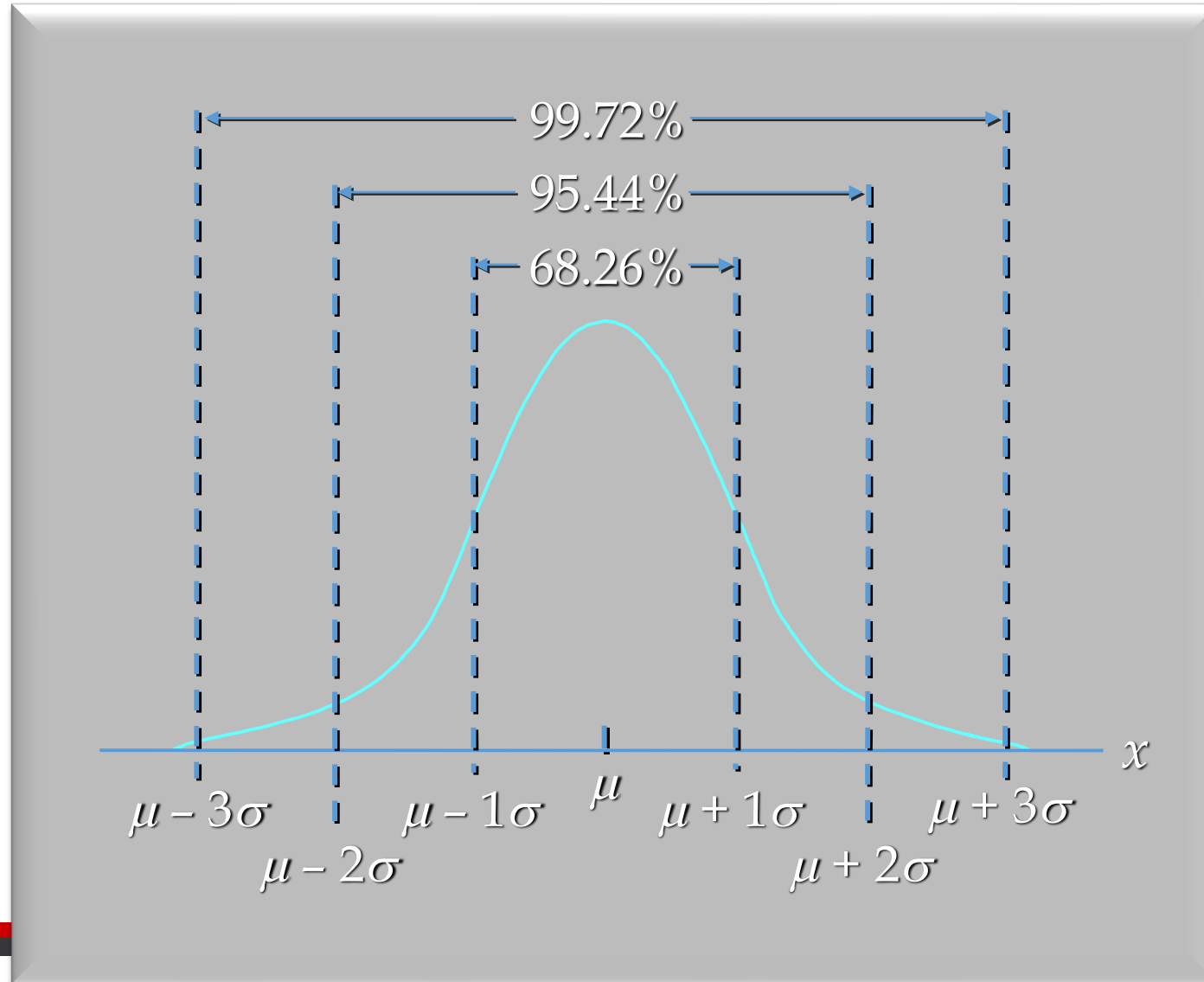

WHAT IS STATISTICS?

sion)

WE MUDDLE THROUGH LIFE MAKING CHOICES
BASED ON INCOMPLETE INFORMATION...

SHOULD I HAVE THE SOUP?
EVERYTHING ELSE IS SO
EXPENSIVE, AND I DON'T
KNOW WHO'S PAYING... ARE
STATISTICIANS STINGY? I'VE
NEVER GONE OUT WITH
ONE BEFORE... THOUGH I
ONCE KNEW A VERY
GENEROUS ACCOUNTANT...

SHOULD I HAVE THE SOUP?
27 OUT OF THE 36 TIMES
I'VE HAD IT, IT WAS PRETTY
GOOD... BUT IS MONDAY THE
REGULAR CHEF'S NIGHT
OFF? AND WHAT IF ALL THE
AIR MOLECULES IN THE
ROOM SUDDENLY FLY UP TO
THE CEILING?



Sampling Distribution of \bar{x} (6 of 10)

Example: St. Andrew's College

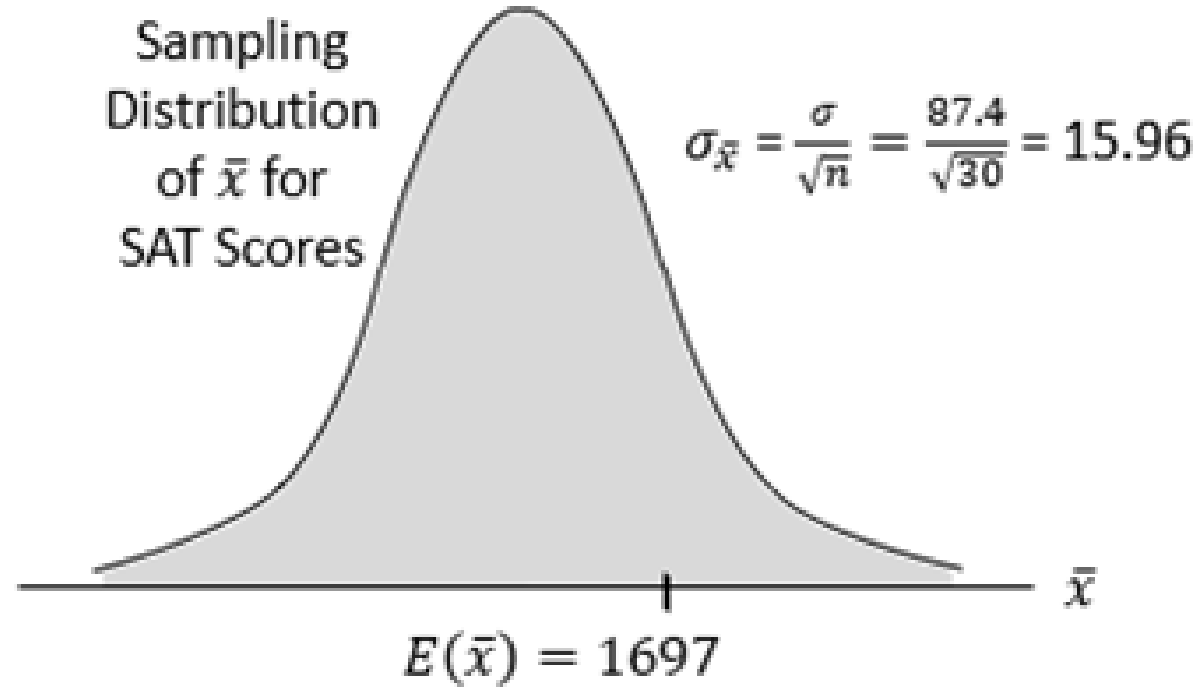

Sampling Distribution of \bar{x} (7 of 10)

Example: St. Andrew's College

- What is the probability that a simple random sample of 30 applicants will provide an estimate of the population mean SAT score that is within ± 10 of the actual population mean μ ?
- In other words, what is the probability that \bar{x} will be between 1687 and 1707?

Sampling Distribution of \bar{x} (8 of 10)

Example: St. Andrew's College

Step 1: Calculate the z-value at the upper endpoint of the interval.

$$z = \frac{(1707 - 1697)}{15.96} = 0.63$$

Step 2: Find the area under the curve to the left of the upper endpoint.

$$P(z \leq 0.63) = 0.7357$$

Sampling Distribution of \bar{x} (9 of 10)

Example: St. Andrew's College

Cumulative Probabilities for the Standard Normal Distribution

z	.00	.01	.02	.03	.04
.
.5	.6915	.6950	.6985	.7019	.7054
.6	.7257	.7291	.7324	.737	.7389
.7	.7580	.7611	.7642	.7673	.7704
.8	.7881	.7910	.7939	.7967	.7995
.9	.8159	.8186	.8212	.8238	.8264

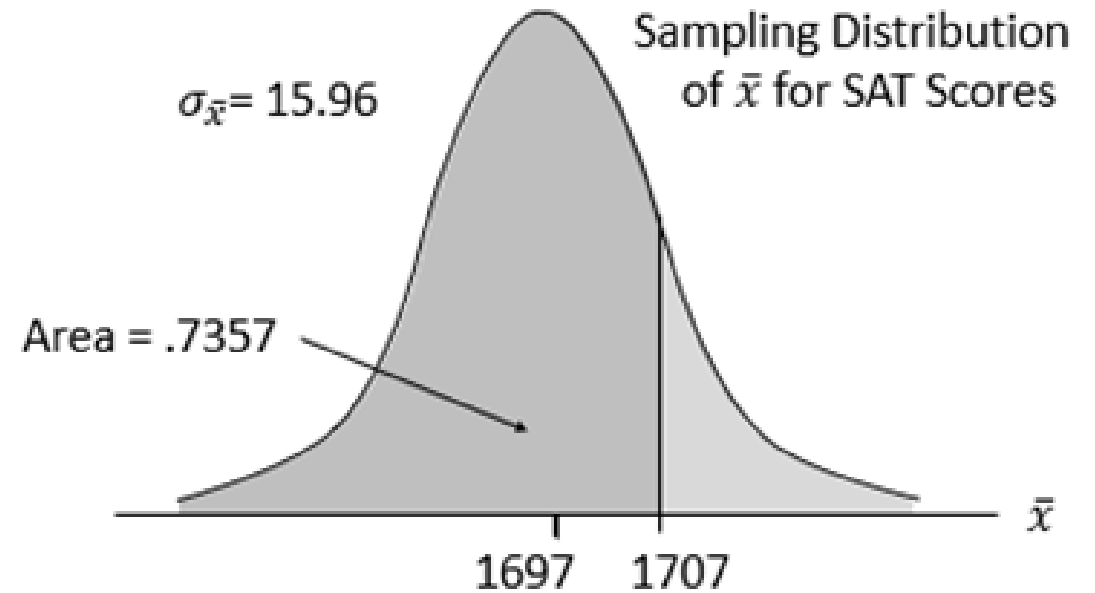

Sampling Distribution of \bar{x} (10 of 10)

Example: St. Andrew's College

Step 3: Calculate the z-value at the lower endpoint of the interval.

$$z = \frac{(1687 - 1697)}{15.96} = -0.63$$

Step 4: Find the area under the curve to the left of the lower endpoint.

$$P(z \leq -0.63) = 0.2643$$

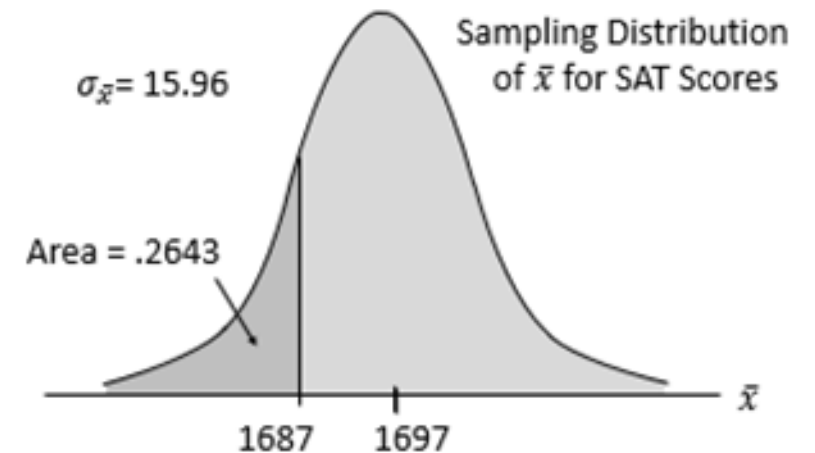

Sampling Distribution of \bar{x} for SAT Scores

Example: St. Andrew's College

Step 5: Calculate the area under the curve between the lower and upper endpoints of the interval.

$$\begin{aligned} P(-0.68 \leq \bar{x} \leq 0.68) &= P(z \leq 0.68) - P(z \leq -0.68) \\ &= 0.7357 - 0.2643 \\ &= 0.4714 \end{aligned}$$

The probability that the estimate of population mean SAT score will be between 1687 and 1707 is:

$$P(1687 \leq \bar{x} \leq 1707) = 0.4714$$

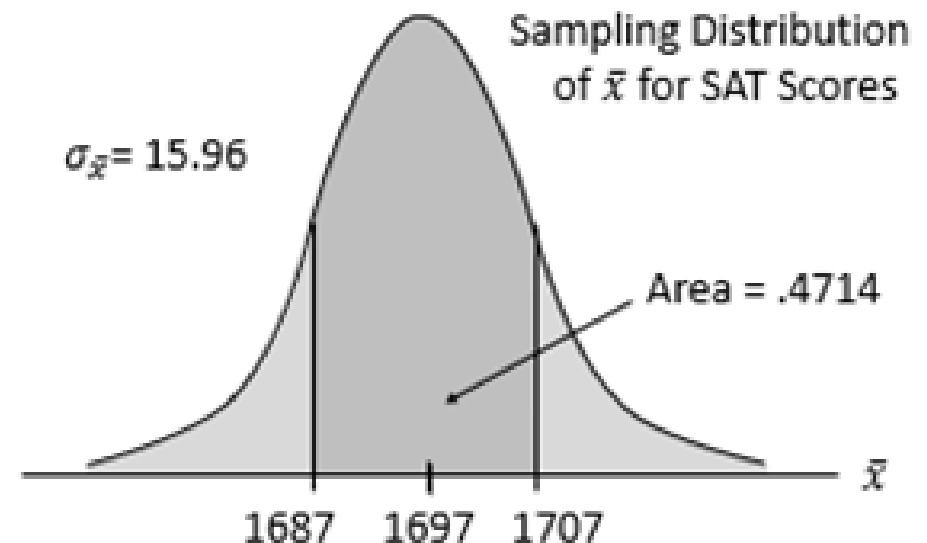

Relationship Between the Sample Size and the Sampling Distribution of \bar{x} (1 of 4)

Example: St. Andrew's College

- Suppose we select a simple random sample of 100 applicants instead of the 30 originally considered.
- $E(\bar{x}) = \mu$ regardless of the sample size. In our example, $E(\bar{x})$ remains at 1697.
- Whenever the sample size is increased, the standard error of the mean $\sigma_{\bar{x}}$ is decreased. With the increase in the sample size to $n = 100$, the standard error of the mean is decreased from 15.96 to:

$$\sigma_{\bar{x}} = \sqrt{\frac{N-n}{N-1}} \left(\frac{\sigma}{\sqrt{n}} \right) = \sqrt{\frac{900-100}{900-1}} \left(\frac{87.4}{\sqrt{100}} \right) = 0.9433(8.74) = 8.2$$

Relationship Between the Sample Size and the Sampling Distribution of \bar{x} (2 of 4)

Example: St. Andrew's College

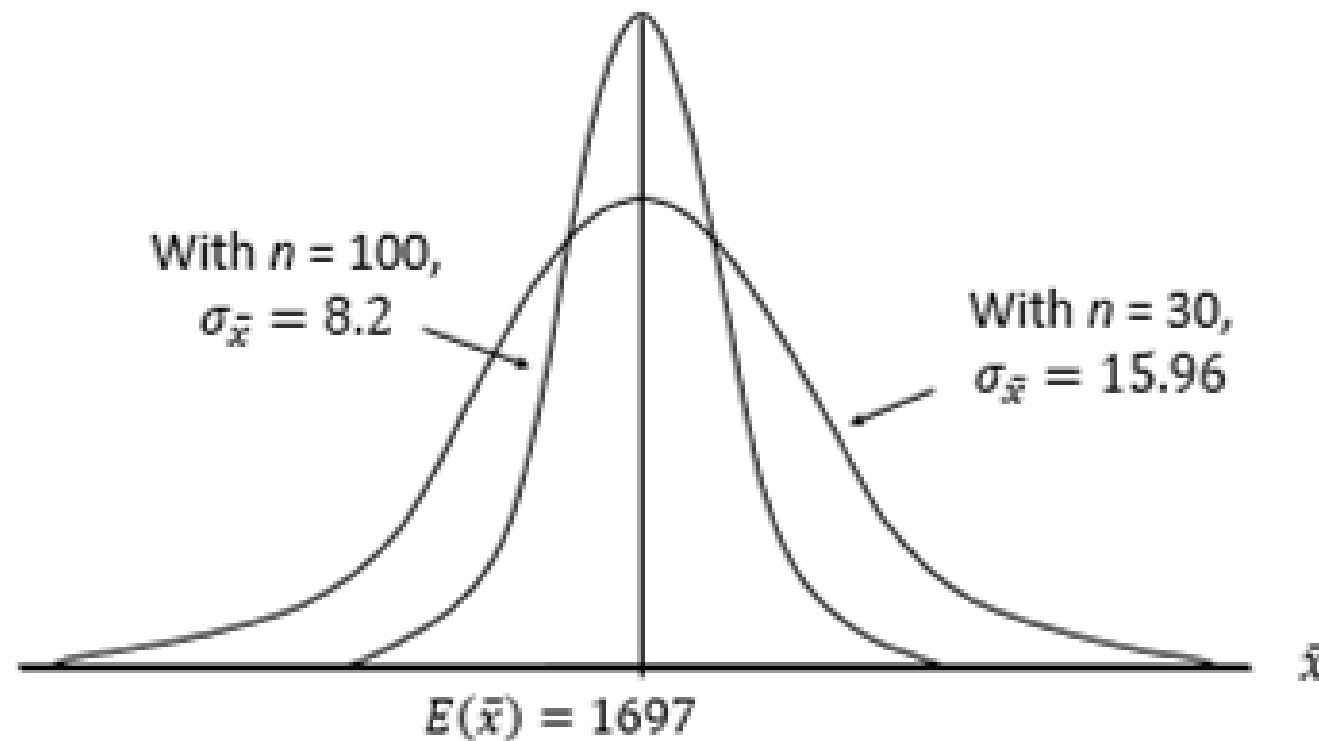

Relationship Between the Sample Size and the Sampling Distribution of \bar{x} (3 of 4)

Example: St. Andrew's College

- Recall that when $n = 30$, $P(1687 \leq \bar{x} \leq 1707) = .4714$.
- We follow the same steps to solve for $P(1687 \leq \bar{x} \leq 1707)$ when $n = 100$ as we showed earlier when $n = 30$.
- Now, with $n = 100$, $P(1687 \leq \bar{x} \leq 1707) = .7776$.
- Because the sampling distribution with $n = 100$ has a smaller standard error, the values of \bar{x} have less variability and tend to be closer to the population mean than the values of \bar{x} with $n = 30$.

Relationship Between the Sample Size and the Sampling Distribution of \bar{x} (4 of 4)

Example: St. Andrew's College

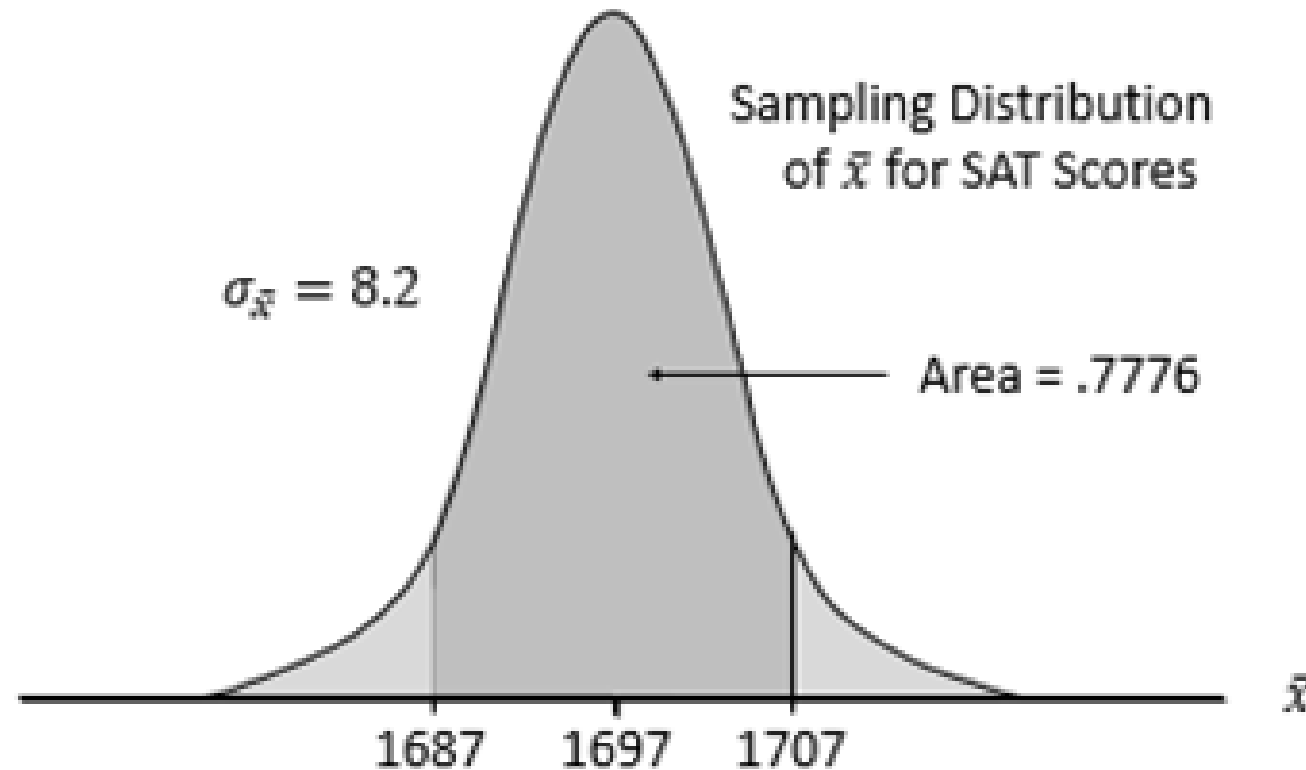

Other Sampling Methods

- Stratified Random Sampling
- Cluster Sampling
- Systematic Sampling
- Convenience Sampling
- Judgment Sampling

Stratified Random Sampling (分層隨機抽樣)

- The population is first divided into groups of elements called strata.
- Each element in the population belongs to one and only one stratum.
- Best results are obtained when the elements within each stratum are as much alike as possible (i.e., a homogeneous group).

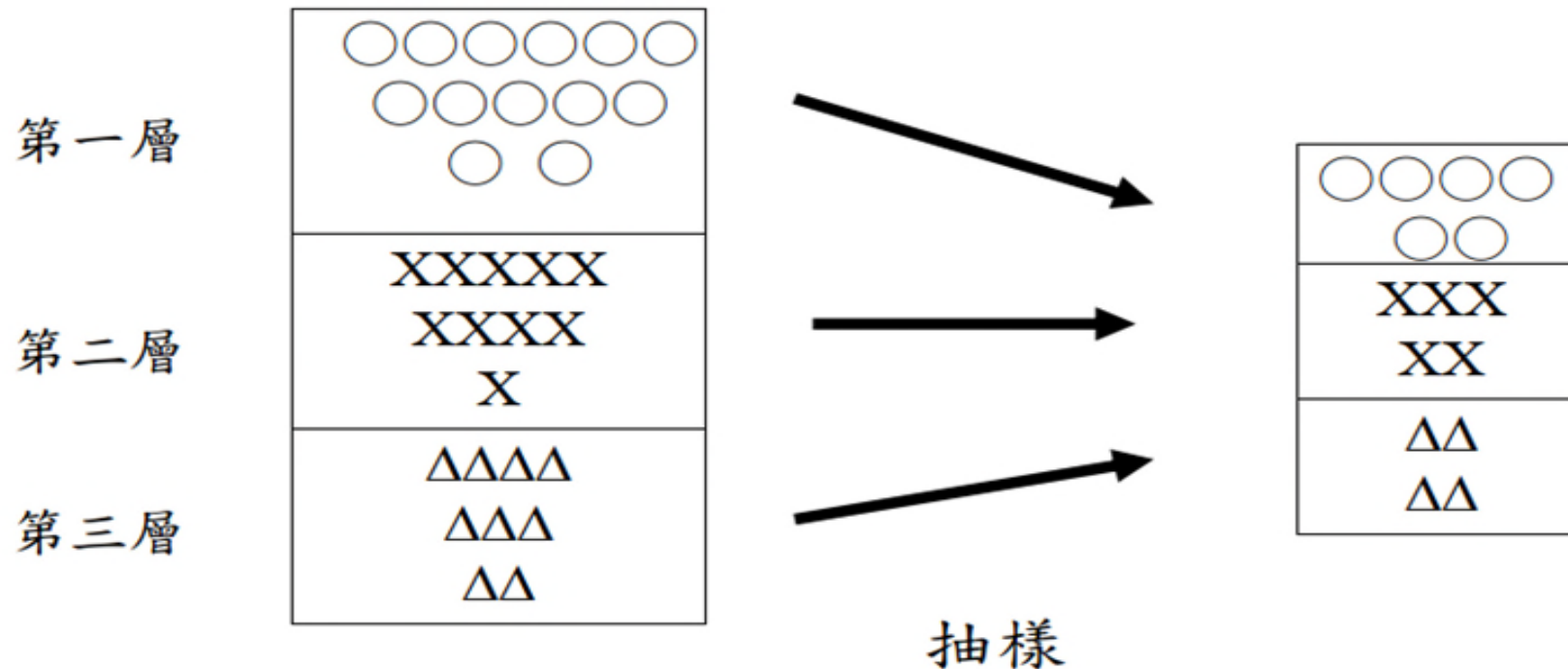

Stratified Random Sampling, Part 2

- A simple random sample is taken from each stratum.
- Formulas are available for combining the stratum sample results into one population parameter estimate.
- Advantage: If strata are homogeneous, this method provides results that are as “precise” as simple random sampling but with a smaller total sample size.
- Example: The basis for forming the strata might be department, location, age, industry type, and so on.

Cluster Sampling (1 of 2) (群集抽樣)

- The population is first divided into separate groups of elements called clusters.
- Ideally, each cluster is a representative small-scale version of the population (i.e., heterogeneous group).
- A simple random sample of the clusters is then taken.
- All elements within each sampled (chosen) cluster form the sample.

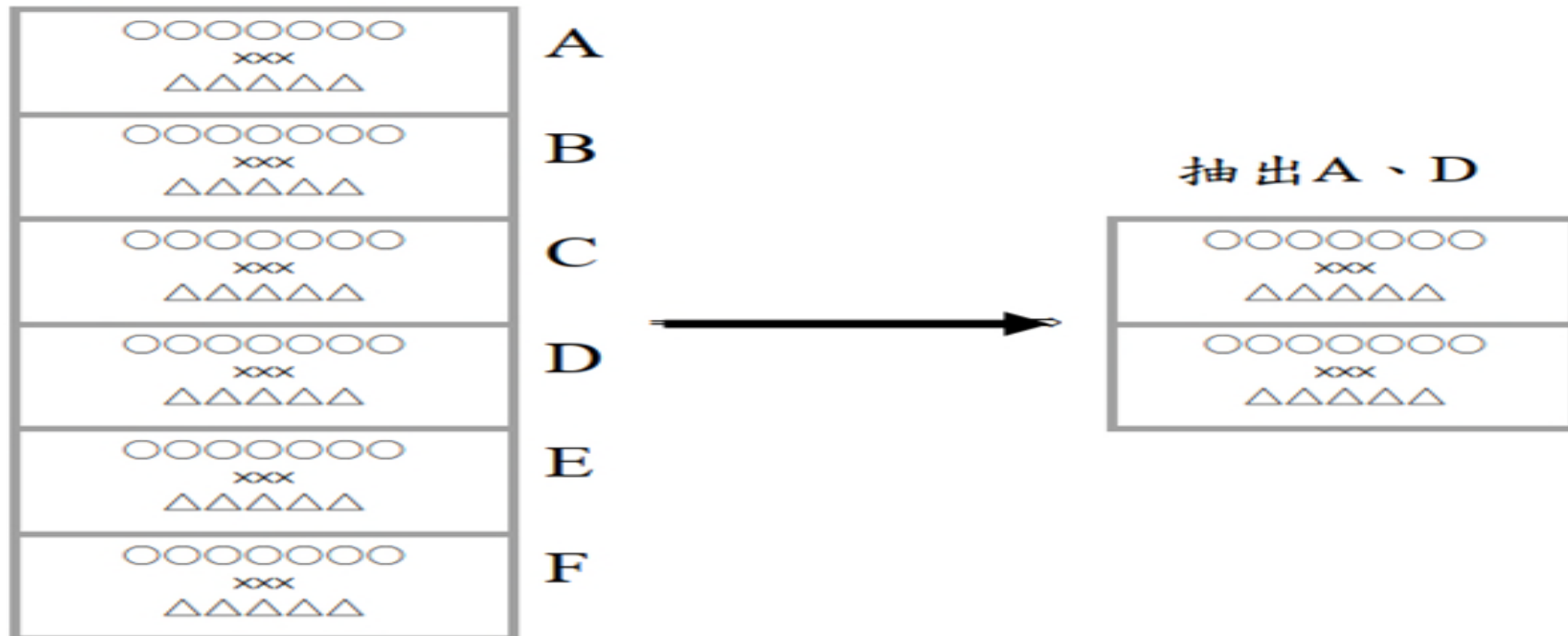

Cluster Sampling (2 of 2)

- Example: A primary application is area sampling, where clusters are city blocks or other well-defined areas.
- Advantage: The close proximity of elements can be cost effective (i.e., many sample observations can be obtained in a short time).
- Disadvantage: This method generally requires a larger total sample size than simple or stratified random sampling.

Systematic Sampling (1 of 2) (系統抽樣)

- If a sample size of n is desired from a population containing N elements, we might sample one element for every N/n elements in the population.
- We randomly select one of the first N/n elements from the population list.
- We then select every N/n^{th} element that follows in the population list.

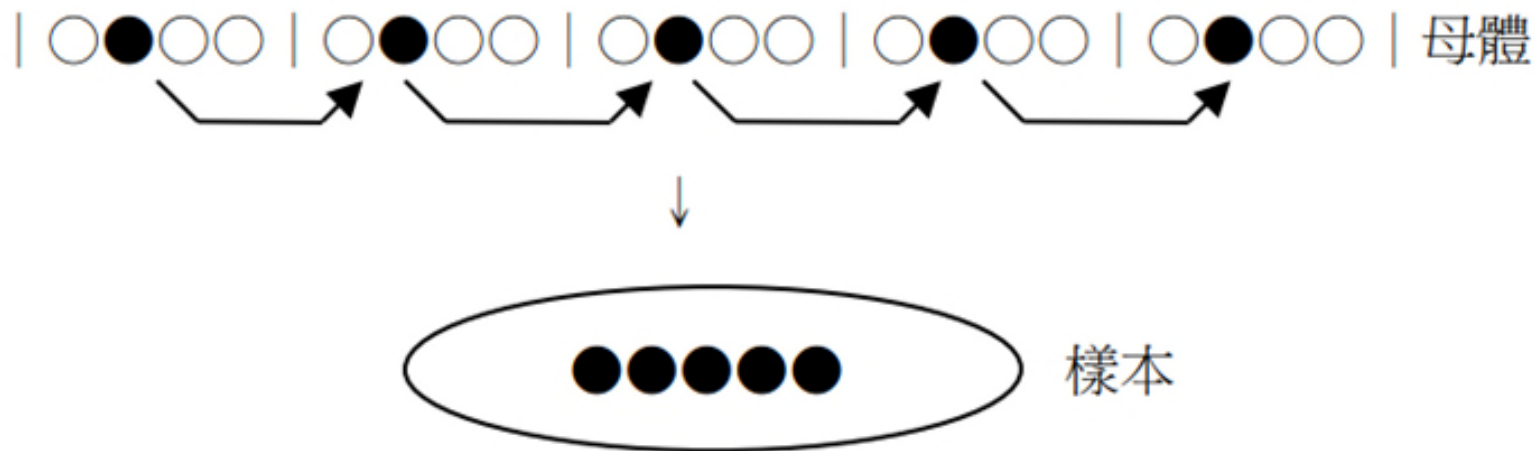

Systematic Sampling (2 of 2)

- This method has the properties of a simple random sample, especially if the list of the population elements is a random ordering.
- Advantage: The sample usually will be easier to identify than it would be if simple random sampling were used.
- Example: Selecting every 100th listing in a telephone book after the first randomly selected listing.

Convenience Sampling (便利抽樣)

- It is a nonprobability sampling technique. Items are included in the sample without known probabilities of being selected.
- The sample is identified primarily by convenience.
- Example: A professor conducting research might use student volunteers to constitute a sample.
- Advantage: Sample selection and data collection are relatively easy.
- Disadvantage: It is impossible to determine how representative of the population the sample is.

Judgment Sampling (立意抽樣)

- The person most knowledgeable on the subject of the study selects elements of the population that he or she feels are most representative of the population.
- It is a nonprobability sampling technique.
- Example: A reporter might sample three or four senators, judging them as reflecting the general opinion of the senate.
- Advantage: It is a relatively easy way of selecting a sample.
- Disadvantage: The quality of the sample results depends on the judgment of the person selecting the sample.

Recommendation

- It is recommended that probability sampling methods (simple random, stratified, cluster, or systematic) be used.
- For these methods, formulas are available for evaluating the “goodness” of the sample results in terms of the closeness of the results to the population parameters being estimated.
- An evaluation of the goodness cannot be made with non-probability (convenience or judgment) sampling methods.

Chapter 8 - Interval Estimation

8.1 – Population Mean: σ Known

8.2 – Population Mean: σ Unknown

8.3 – Determining the Sample Size

8.4 – Population Proportion

8.5 – Big Data and Confidence Intervals



Margin of Error and the Interval Estimate

- A point estimator cannot be expected to provide the exact value of the population parameter.
- An interval estimate can be computed by adding and subtracting a margin of error to the point estimate.

$$\text{Point estimate} \pm \text{Margin of error}$$

- The purpose of an interval estimate is to provide information about how close the point estimate is to the value of the parameter.

統計估計

- 對於母體參數的估計，分為點估計、區間估計兩種。
 - 點估計多半會是最有可能的數值，或是樣本平均數、樣本變異數。
 - 區間估計則是點估計加上最大誤差(Marginal Error)為範圍，例如：
$$\bar{x} \pm \text{Margin of Error}$$
- 最大誤差與容許錯誤、誤差分配有關。

Meaning of C% Confidence

- Because 90% of all the intervals constructed using $\bar{x} \pm 1.645\sigma_{\bar{x}}$ will contain the population mean, we say that we are 90% confident that the interval $\bar{x} \pm 1.645\sigma_{\bar{x}}$ includes the population mean, μ .
- We say that this interval has been established at the 90% confidence level.
- The value 0.90 is referred to as the confidence coefficient.

Interval Estimate of a Population Mean: σ Unknown

- If an estimate of the population standard deviation, σ , cannot be developed prior to sampling, we use the sample standard deviation, s , to estimate σ .
- This is the σ unknown case.
- In this case, the interval estimate for μ is based on the t distribution.
- We'll assume for now that the population is normally distributed.

t Distribution (1 of 4)

- William Gosset, writing under the name “Student,” is the founder of the t distribution.
- Gosset was an Oxford graduate in mathematics and worked for the Guinness Brewery in Dublin.
- He developed the t distribution while working on small-scale materials and temperature experiments.



<https://media.istockphoto.com/photos/col-d-pint-of-guinness-original-on-a-white-background-picture-id458589987>

Student - William Sealy
Gosset (1876 - 1937)



t Distribution (2 of 4)

- The t distribution is a family of similar probability distributions.
- A specific t distribution depends on a parameter known as the degrees of freedom.
- Degrees of freedom refer to the number of independent pieces of information that go into the computation of s .
- A t distribution with more degrees of freedom has less dispersion.
- As the degrees of freedom increase, the difference between the t distribution and the standard normal probability distribution becomes smaller and smaller.

t Distribution (3 of 4)

- For more than 100 degrees of freedom, the standard normal z value provides a good approximation to the t value.
- The standard normal z values can be found in the infinite degrees (∞) row of the t distribution table.

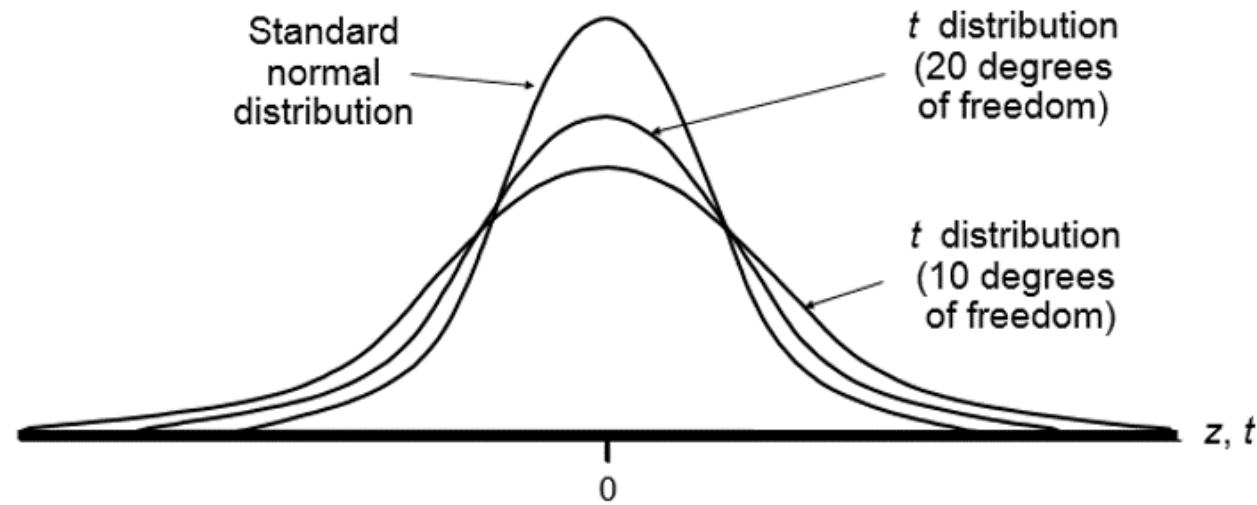

t Distribution (4 of 4)

Degrees of Freedom	Area in Upper Tail					
	.20	.10	.05	.025	.01	.005
.
50	.849	1.299	1.676	2.009	2.403	2.678
60	.848	1.296	1.671	2.000	2.390	2.660
80	.846	1.292	1.664	1.990	2.374	2.639
100	.845	1.290	1.660	1.984	2.364	2.626
∞	.842	1.282	1.645	1.960	2.326	2.576

(bottom row is standard normal z values)

Interval Estimate of a Population Mean: σ Unknown (1 of 5)

Interval Estimate of μ :

$$\bar{x} \pm t_{\alpha/2} \frac{s}{\sqrt{n}}$$

Where:

\bar{x} = the sample mean

$1 - \alpha$ = the confidence coefficient.

$t_{\alpha/2}$ = the t -value providing an area of $\alpha/2$ in the upper tail of the t distribution with $n - 1$ degrees of freedom.

s = the sample standard deviation

n = the sample size

Interval Estimate of a Population Mean: σ Unknown (2 of 5)

Example: Apartment Rents

A reporter for a student newspaper is writing an article on the cost of off-campus housing. A sample of 16 one-bedroom apartments within 1 kilometer of campus resulted in a sample mean of \$750 per month and a sample standard deviation of \$55.

Let us provide a 95% confidence interval estimate of the mean rent per month for the population of one-bedroom apartments within 1 kilometer of campus. We will assume this population to be normally distributed.

Interval Estimate of a Population Mean: σ Unknown (3 of 5)

- At 95% confidence, $\alpha = 0.05$ and $\alpha/2 = 0.025$.
- $t_{0.025}$ is based on $n - 1 = 16 - 1 = 15$ degrees of freedom.

Degrees of Freedom	Area in Upper Tail					
	.20	.10	.05	.025	.01	.005
15	.866	1.341	1.753	2.131	2.602	2.947
16	.865	1.337	1.746	2.120	2.583	2.921
17	.863	1.333	1.740	2.110	2.567	2.898
18	.862	1.330	1.734	2.101	2.520	2.878
19	.861	1.328	1.729	2.093	2.539	2.861
.

Interval Estimate of a Population Mean: σ Unknown (4 of 5)

Interval Estimate

$$\bar{x} \pm t_{.025} \frac{s}{\sqrt{n}}$$

$$750 \pm 2.131 \frac{55}{\sqrt{16}} = 750 \pm 29.30$$

We are 95% confident that the mean rent per month for the population of one-bedroom apartments within 1 kilometer of campus is between \$720.70 and \$779.30.

Interval Estimate of a Population Mean: σ Unknown (5 of 5)

Adequate Sample Size

- Usually, a sample size of at least 30 is adequate when using a t interval to estimate a population mean.
- If the population distribution is highly skewed or contains outliers, a sample size of 50 or more is recommended.
- If the population is not normally distributed but is roughly symmetric, a sample size as small as 15 will suffice.
- If the population is believed to be at least approximately normal, a sample size of less than 15 can be used.

Summary of Interval Estimation Procedures for a Population Mean

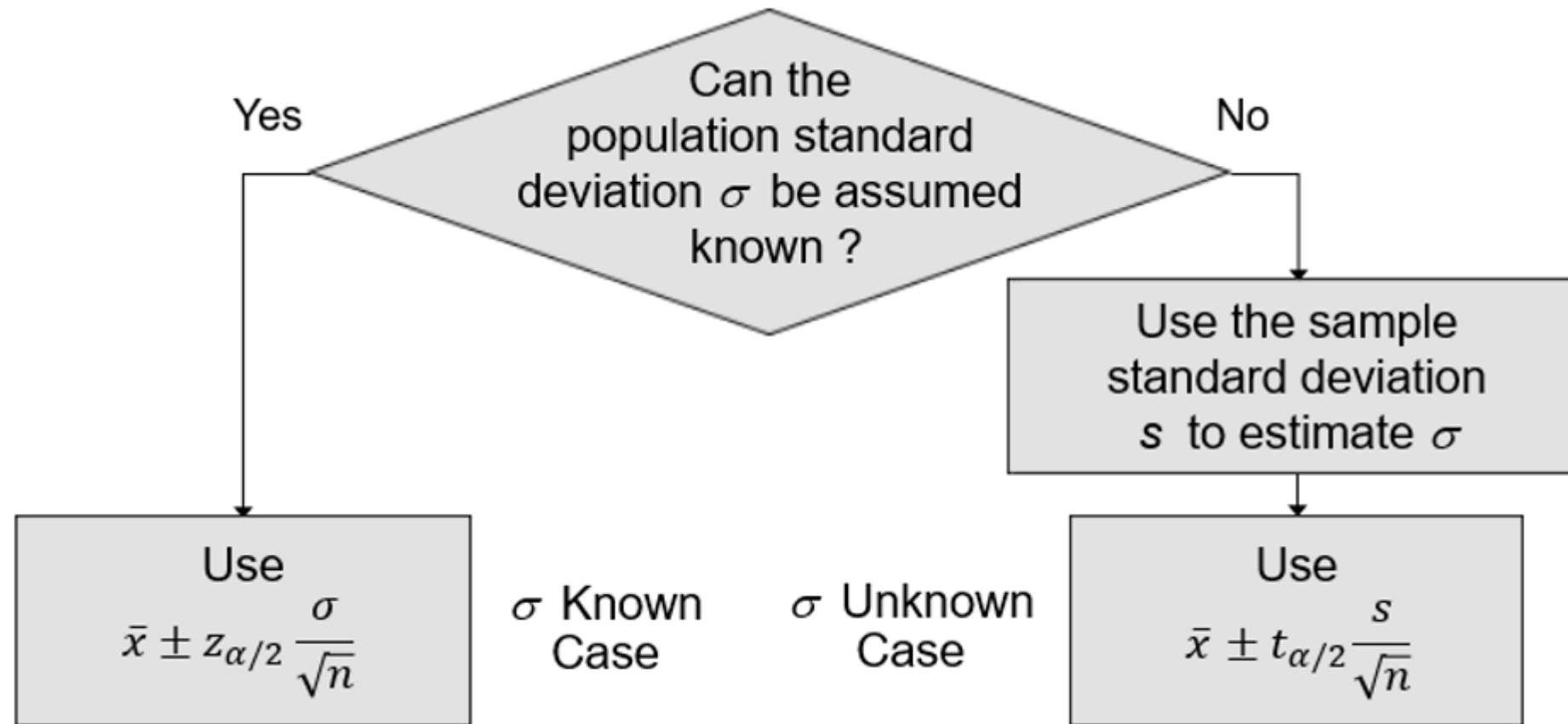

Sample Size for an Interval Estimate of a Population Mean (1 of 4)

- Let E = the desired margin of error.
- E is the amount added to and subtracted from the point estimate to obtain an interval estimate.
- If a desired margin of error is selected prior to sampling, the sample size necessary to satisfy the margin of error can be determined.

- Margin of error
$$E = z_{\alpha/2} \frac{\sigma}{\sqrt{n}}$$

- Necessary sample size
$$n = \frac{(z_{\alpha/2})^2 \sigma^2}{E^2}$$

Sample Size for an Interval Estimate of a Population Mean (2 of 4)

The Necessary Sample Size equation requires a value for the population standard deviation, σ .

If σ is unknown, a preliminary or planning value for σ can be used in the equation.

1. Use the estimate of the population standard deviation computed in a previous study.
2. Use a pilot study to select a preliminary sample and use the sample standard deviation from the study.
3. Use judgment or a “best guess” for the value of σ .

Sample Size for an Interval Estimate of a Population Mean (3 of 4)

Example: Discount Sounds

Recall that Discount Sounds is evaluating a potential location for a new retail outlet based in part on the mean annual income of the individuals in the marketing area of the new location.

Suppose that Discount Sounds' management team wants an estimate of the population mean such that there is a 0.95 probability that the sampling error is \$500 or less.

How large a sample size is needed to meet the required precision?

Sample Size for an Interval Estimate of a Population Mean (4 of 4)

$$E = z_{\alpha/2} \frac{\sigma}{\sqrt{n}}$$

$E = 500$, $\sigma = 4,500$, at 95% confidence $z_{0.025} = 1.96$

$$n = \frac{(z_{\alpha/2})^2 \sigma^2}{E^2} = \frac{(1.96)^2 (4500)^2}{500^2} = 311.17 \approx 312$$

A sample size of 312 is needed to reach the desired precision of ± 500 at 95% confidence.

Interval Estimate of a Population Proportion (1 of 5)

- The general form of an interval estimate of a population proportion is:

$$\bar{p} \pm \text{Margin of error}$$

- The sampling distribution of \bar{p} plays a key role in computing the margin of error for this interval estimate.
- The sampling distribution of \bar{p} can be approximated by a normal distribution whenever $np \geq 5$ and $n(1 - p) \geq 5$.

Interval Estimate of a Population Proportion (2 of 5)

Normal Approximation of the Sampling Distribution of \bar{p} .

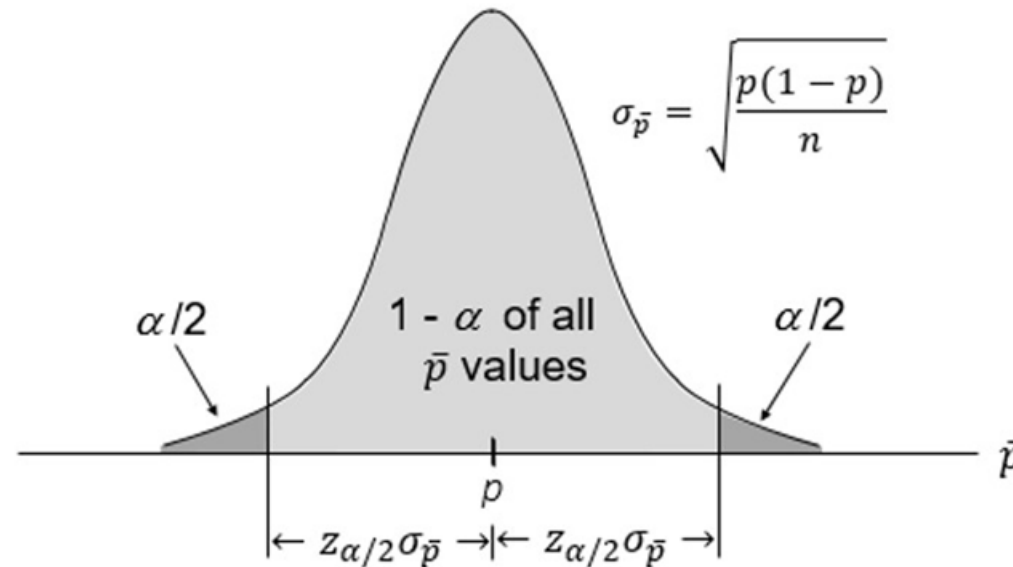

Interval Estimate of a Population Proportion (3 of 5)

Interval Estimate of μ :

$$\bar{p} \pm z_{\alpha/2} \sqrt{\frac{\bar{p}(1 - \bar{p})}{n}}$$

Where:

\bar{p} = the sample proportion

$1 - \alpha$ = the confidence coefficient

$z_{\alpha/2}$ = the z-value providing an area of $\alpha/2$ in the upper tail of the standard normal distribution.

n = the sample size

Interval Estimate of a Population Proportion (4 of 5)

Example: Political Science, Inc.

Political Science, Inc. (PSI) specializes in voter polls and surveys designed to keep political office seekers informed of their position in a race.

Using telephone surveys, PSI interviewers ask registered voters who they would vote for if the election were held that day.

In a current election campaign, PSI has just found that 220 registered voters, out of 500 contacted, favor a particular candidate. PSI wants to develop a 95% confidence interval estimate for the proportion of the population of registered voters that favor the candidate.

Interval Estimate of a Population Proportion (5 of 5)

$$\bar{p} \pm z_{\alpha/2} \sqrt{\frac{\bar{p}(1 - \bar{p})}{n}}$$

Where $n = 500$, $\bar{p} = 220/500 = 0.44$, $z_{\alpha/2} = 1.96$

$$0.44 \pm 1.96 \sqrt{\frac{0.44(1 - 0.44)}{500}}$$

$$0.44 \pm 0.0435$$

PSI is 95% confident that the proportion of all voters that favor the candidate is between 0.3965 and 0.4835.

Sample Size for an Interval Estimate of a Population Proportion (1 of 4)

- Margin of error $E = z_{\alpha/2} \sqrt{\frac{\bar{p}(1-\bar{p})}{n}}$

- Solving for n , the necessary sample size is $n = \frac{(z_{\alpha/2})^2 \bar{p}(1 - \bar{p})}{E^2}$

- However, \bar{p} will not be known until after we have selected the sample. Therefore, we will use the planning value p^* for \bar{p} .

Sample Size for an Interval Estimate of a Population Proportion (2 of 4)

Necessary Sample Size

$$n = \frac{(z_{\alpha/2})^2 p^* (1 - p^*)}{E^2}$$

The planning value p^* can be chosen by:

1. Using the sample proportion from a previous sample of the same or similar size.
2. Selecting a preliminary sample and using the sample proportion from that sample.
3. Using judgment or a “best guess” for the p^* value.
4. Otherwise, use $p^* = 0.5$.

Sample Size for an Interval Estimate of a Population Proportion (3 of 4)

Example: Political Science, Inc.

Suppose that PSI would like a 0.99 probability that the sample proportion is within ± 0.03 of the population proportion.

How large a sample size is needed to meet the required precision? (A previous sample of similar units yielded 0.44 for the sample proportion.)

Sample Size for an Interval Estimate of a Population Proportion (4 of 4)

$E = 0.03$, $p^* = 0.44$, and at 99% confidence, $z_{0.005} = 2.576$.

$$n = \frac{(z_{\alpha/2})^2 p^*(1 - p^*)}{E^2}$$

$$n = \frac{(2.576)^2 (0.44)(0.56)}{(0.03)^2} = 1817$$

A sample size of 1817 is needed to reach the desired precision of ± 0.03 at 99% confidence.

Note: We used 0.44 as the best estimate of p . If no information is available about p , then 0.5 is often used because it provides the greatest possible sample size. If we had used $p^* = 0.5$, the recommended n would have been 1843.

抽取1,000份樣本的原因

- 民意、市場調查的多為封閉問卷，有興趣的多為某個問項佔的比例，例如：某位候選人的支持程度→二項分配。
- 在信心水準為95%及最大誤差不大於3%的要求下：

$$1.96 \times \sqrt{\frac{p(1-p)}{n}} \leq 0.03$$

$$\Leftrightarrow \sqrt{n} \geq \frac{1.96 \sqrt{p(1-p)}}{0.03} \cong \frac{1.96 \times 1/2}{0.03}$$

$$\Leftrightarrow n \geq 1,067$$

多少樣本才足夠？

■抽樣時常見的迷思：

→樣本數必須達到母體的一定比例？

範例(1)一般抽血不多於 10 c.c.，不論大人或小孩。

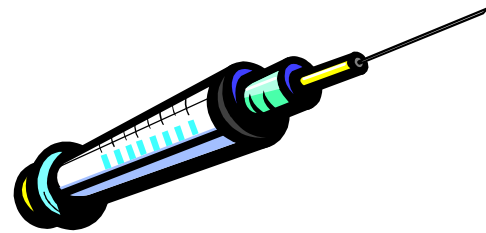

範例(2)台灣與美國人口數差了10倍以上，但民意調查多半只抽1,000份左右。

Chapter 9 - Hypothesis Tests

9.1 - Developing Null and Alternative Hypotheses

9.2 - Type I and Type II Errors

9.3 - Population Mean: σ Known

9.4 - Population Mean: σ Unknown

9.5 - Population Proportion

9.6 – Hypothesis Testing and Decision Making

9.7 – Calculating the Probability of Type II Errors

9.8 – Determining the Sample Size for a Hypothesis Test about a Population Mean

9.9 – Big Data and Hypothesis Testing

		Decision From Testing [†]	
		Reject H_0 [†]	Fail to Reject H_0 [†]
Truth [†]	H_0 is TRUE [†]	Type I Error [†] (False Positive, α) [†]	Correct Decision [†] (True Positive) [†]
	H_0 is FALSE [†]	Correct Decision [†] (True Negative) [†]	Type II Error [†] (False Negative, β) [†]

Hypothesis Testing (假設檢定)

- Hypothesis testing can be used to determine whether a statement about the value of a population parameter should or should not be rejected.
- The null hypothesis (虛無假設), denoted by H_0 , is a tentative assumption about a population parameter.
- The alternative hypothesis (對立假設), denoted by H_a , is the opposite of what is stated in the null hypothesis.
- The hypothesis testing procedure uses data from a sample to test the two competing statements indicated by H_0 and H_a .

	有病者	無病者
檢驗結果 陽性 +	真陽性 a	偽陽性 c
檢驗結果 陰性 -	偽陰性 b	真陰性 d

https://epaper.ntuh.gov.tw/health/201606/images/health_5_clip_image002.jpg

敏感性 = $\frac{a}{a+b}$ · 真陽性率：有病者檢驗結果為陽性的比率

特異性 = $\frac{d}{c+d}$ · 真陰性率：無病者檢驗結果為陰性的比率

虛無假設 H_0 為沒病，偽陽性為型一誤差、偽陰性為型二誤差。

- 型一誤差 (Type-1 Error) 等於 $P(\text{拒絕 } H_0 | H_0 \text{ 為真})$
- 型二誤差 (Type-2 Error) 等於 $P(\text{不拒絕 } H_0 | H_0 \text{ 不為真})$

Developing Null and Alternative Hypotheses (1 of 4)

- It is not always obvious how the null and alternative hypotheses should be formulated.
- Care must be taken to structure the hypotheses appropriately so that the test conclusion provides the information the researcher wants.
- The context of the situation is very important in determining how the hypotheses should be stated.
- In some cases it is easier to identify the alternative hypothesis first. In other cases the null is easier.
- Correct hypothesis formulation will take practice.

Developing Null and Alternative Hypotheses (2 of 4)

Alternative Hypothesis as a Research Hypothesis

- Many applications of hypothesis testing involve an attempt to gather evidence in support of a research hypothesis.
- In such cases, it is often best to begin with the alternative hypothesis and make it the conclusion that the researcher hopes to support.
- The conclusion that the research hypothesis is true is made if the sample data provides sufficient evidence to show that the null hypothesis can be rejected.

Example: A new teaching method is developed that is believed to be better than the current method.

Null Hypothesis: The new method is no better than the old method.

Alternative Hypothesis: The new teaching method is better.

Developing Null and Alternative Hypotheses (3 of 4)

Example: A new sales force bonus plan is developed in an attempt to increase sales.

Null Hypothesis: The new bonus plan will not increase sales.

Alternative Hypothesis: The new bonus plan will increase sales.

Example: A new drug is developed with the goal of lowering blood pressure more than the existing drug.

Null Hypothesis: The new drug does not lower blood pressure more than the existing drug.

Alternative Hypothesis: The new drug lowers blood pressure more than the existing drug.

Developing Null and Alternative Hypotheses (4 of 4)

Null Hypothesis as an Assumption to be Challenged

- We might begin with a belief or assumption that a statement about the value of a population parameter is true.
- We then use a hypothesis test to challenge the assumption and determine if there is statistical evidence to conclude that the assumption is incorrect.
- In these situations, it is helpful to develop the null hypothesis first.

Example: The label on a soft drink bottle states that it contains 67.6 fluid ounces.

Null Hypothesis: The label is correct. $\mu \geq 67.6$ ounces.

Alternative Hypothesis: The label is incorrect. $\mu < 67.6$ ounces.

Summary of Forms for Null and Alternative Hypotheses

- The equality part of the hypotheses always appears in the null hypothesis.
- In general, a hypothesis test about the value of a population mean μ must take one of the following three forms (where μ_0 is the hypothesized value of the population mean).

1. One-tailed, lower tail: $H_0: \mu \geq \mu_0$ $H_a: \mu < \mu_0$

2. One-tailed, upper tail: $H_0: \mu \leq \mu_0$ $H_a: \mu > \mu_0$

3. Two-tailed: $H_0: \mu = \mu_0$ $H_a: \mu \neq \mu_0$

Null and Alternative Hypotheses (1 of 2)

Example: Metro EMS

A major west coast city provides one of the most comprehensive emergency medical services in the world. Operating in a multiple hospital system with approximately 20 mobile medical units, the service goal is to respond to medical emergencies with a mean time of 12 minutes or less.

The director of medical services wants to formulate a hypothesis test that could use a sample of emergency response times to determine whether or not the service goal of 12 minutes or less is being achieved.

Null and Alternative Hypotheses (2 of 2)

$H_0: \mu \leq 12$ The emergency service is meeting the response goal.
No follow-up action is necessary.

$H_a: \mu > 12$ The emergency service is not meeting the response goal.
Appropriate follow-up action is necessary.

where μ = the mean response time for the population of medical emergency requests.

Type I Error

- Because hypothesis tests are based on sample data, we must allow for the possibility of errors.
- A Type I error is rejecting H_0 when it is true.
- The probability of making a Type I error when the null hypothesis is true as an equality is called the level of significance (顯著水準).
- Applications of hypothesis testing that only control for the Type I error are often called significance tests.

Type II Error

- A Type II error is accepting H_0 when it is false.
- It is difficult to control for the probability of making a Type II error.
- Statisticians avoid the risk of making a Type II error by using “**do not reject H_0** ” rather than “accept H_0 ”.

註：假設檢定的結論只有「**拒絕 H_0** 」和「**不拒絕 H_0** 」。

→ 無法得知真實狀況，根據資料分析結果排除**可能性較低者**！

（另外，拒絕也與對立假設有關係。）。。

Type I and Type II Errors

		Population Condition	
		H_0 True ($\mu \leq 12$)	H_0 False ($\mu > 12$)
Conclusion	Accept H_0 (Conclude $\mu \leq 12$)	Correct Conclusion	Type II Error
	Reject H_0 (Conclude $\mu > 12$)	Type I Error	Correct Conclusion

法律與假設檢定：被告有罪 vs. 被告無罪

In a celebrated criminal case in California (People versus Collins, 1968), a black male and a white female were found guilty of robbery, partly on the basis of a probability argument. Eyewitnesses testified that the robbery had been committed by a couple consisting of a black man with a beard and a moustache, and a white woman with blond hair in a ponytail. They were seen driving a car which was partly yellow. A couple, who matched these descriptions, were later arrested. In court they denied the offence and could not otherwise be positively identified.

A mathematics lecturer gave evidence that the six main characteristics had probabilities as follows:

negro man with beard	1/10
man with moustache	1/4
girl with ponytail	1/10
girl with blond hair	1/3
partly yellow car	1/10
inter-racial couple in car	1/1000

The witness then testified that the product rule of probability theory could be used to multiply these probabilities together to give a probability of 1/12 000 000 that a couple chosen at random would have all these characteristics. The prosecutor asked the jury to infer that there was only one chance in 12 million of the defendants' innocence, and the couple were subsequently convicted.

Comment on the above probability argument.

p-Value Approach to One-Tailed Hypothesis Testing

- The p-value is the probability, computed using the test statistic, that measures the support (or lack of support) provided by the sample for the null hypothesis.
- If the p -value is less than or equal to the level of significance α , the value of the test statistic is in the rejection region.
- Reject H_0 if the p -value $\leq \alpha$.

Suggested Guidelines for Interpreting p-Values

- Less than 0.01: Overwhelming evidence to conclude H_a is true.
- Between 0.01 and 0.05: Strong evidence to conclude H_a is true.
- Between 0.05 and 0.10: Weak evidence to conclude H_a is true.
- Greater than 0.10: Insufficient evidence to conclude H_a is true.

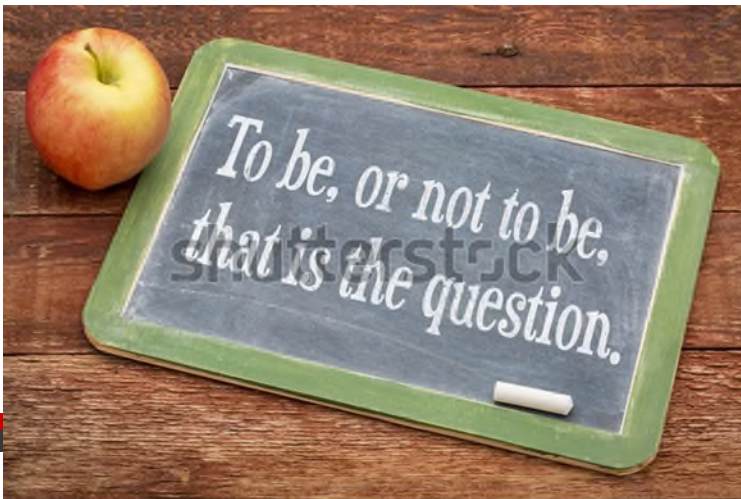

www.shutterstock.com · 246702544





<https://image.shutterstock.com/image-photo/be-not-that-question-text-600w-246702544.jpg>

<https://image.shutterstock.com/image-vector/vector-illustration-hamlet-play-isolated-600w-131784596.jpg>



www.shutterstock.com · 131784596

AZ疫苗的副作用統計

腫		接種部位腫脹 (1/10~1/100)
痛		接種部位疼痛 (54.2%) 頭痛(52.6%) 肌肉痛(44.0%) 關節痛(26.4%)
倦		疲倦(53.1%)
燒		發燒 > 38°C (7.9%) 畏寒(31.9%)
吐		嘔吐 (1/10~1/100)

發生率	症狀
極常見(<1/10)	頭痛、噁心、肌痛、關節痛、注射部位(觸痛、疼痛、發熱、搔癢、瘀青)、倦怠、不適、發熱、發冷
常見(1/10~1/100)	嘔吐、腹瀉、肢體疼痛、接種部位腫脹、紅斑、發燒、類流感症狀、虛弱、暫時性輕度血小板低下症
不常見 (1/100~1/1,000)	淋巴結腫大、食慾下降、頭暈、腹痛、多汗、搔癢、皮疹、蕁麻疹
極罕見(<1/10,000)	血栓合併血小板低下症群(TTS)、格林-巴利症候群(Guillain-Barré syndrome)
目前尚不清楚	立即性過敏、過敏、微血管滲漏症候群、血管性水腫

各種疫苗的副作用比較

Regular (一般；規律)



Irregular (異常)



Extreme (極端)

疫苗／年齡層	AZ 疫苗 (AstraZeneca)	莫德納疫苗 (Moderna)	輝瑞疫苗 (Pfizer/BioNTech)
高齡常見	<p>50 歲以上，發生率高到低</p> <p>施打處發癢腫脹：> 10% 肌痛：40 ~ 50% 施打處疼痛：30 ~ 40% 疲倦：30 ~ 40% 畏寒：20 ~ 30% 頭痛：20 ~ 30% 噁心嘔吐：約 20% 施打處紅腫：10 ~ 20% 發燒：10 ~ 20% 關節痛：10 ~ 20%</p>	<p>64 歲以上，發生率高到低</p> <p>施打處痠痛：70 ~ 80% 疲倦感：30 ~ 40% 頭痛：20 ~ 30% 肌痛：約 20% 關節痛：10 ~ 20% 畏寒：約 10% 發癢：約 10% 淋巴結腫痛：5 ~ 10% 噁心嘔吐：< 5% 發燒：< 5% 施打處紅腫：< 5%</p>	<p>56 歲以上，發生率高到低</p> <p>施打處痠痛：70 ~ 80% 疲倦感：30 ~ 40% 頭痛：20 ~ 30% 肌痛：10 ~ 20% 腹瀉：約 10% 關節痛：約 10% 畏寒：5 ~ 10% 噁心嘔吐：< 5% 發燒：< 5%</p>
少見	<p>嗜睡：約 1% 食慾下降：約 1% 腹痛：約 1% 淋巴結腫大：約 1% 發癢麻疹：約 1% 嚴重過敏：少見，頻率不明 血栓：約 0.0001% (英國統計到 226 例)</p>	<p>接種處發癢：約 1% 單側顏面神經麻痺：約 0.1% 臉部腫脹：約 0.1% 嚴重過敏：少見，頻率不明 心肌炎：極罕見，年輕者約 0.00126% 血栓：極罕見，頻率不明</p>	<p>失眠：約 1% 淋巴結腫大：約 1% 手臂疼痛：約 1% 發癢：約 1% 單側顏面神經麻痺：0.1% 麻疹：約 0.1% 臉部腫脹：約 0.1% 嚴重過敏：極罕見，頻率不明 心肌炎：極罕見，年輕者約 0.00126% 血栓：約 0.0001%</p>

P-value與信賴區間的機率意涵

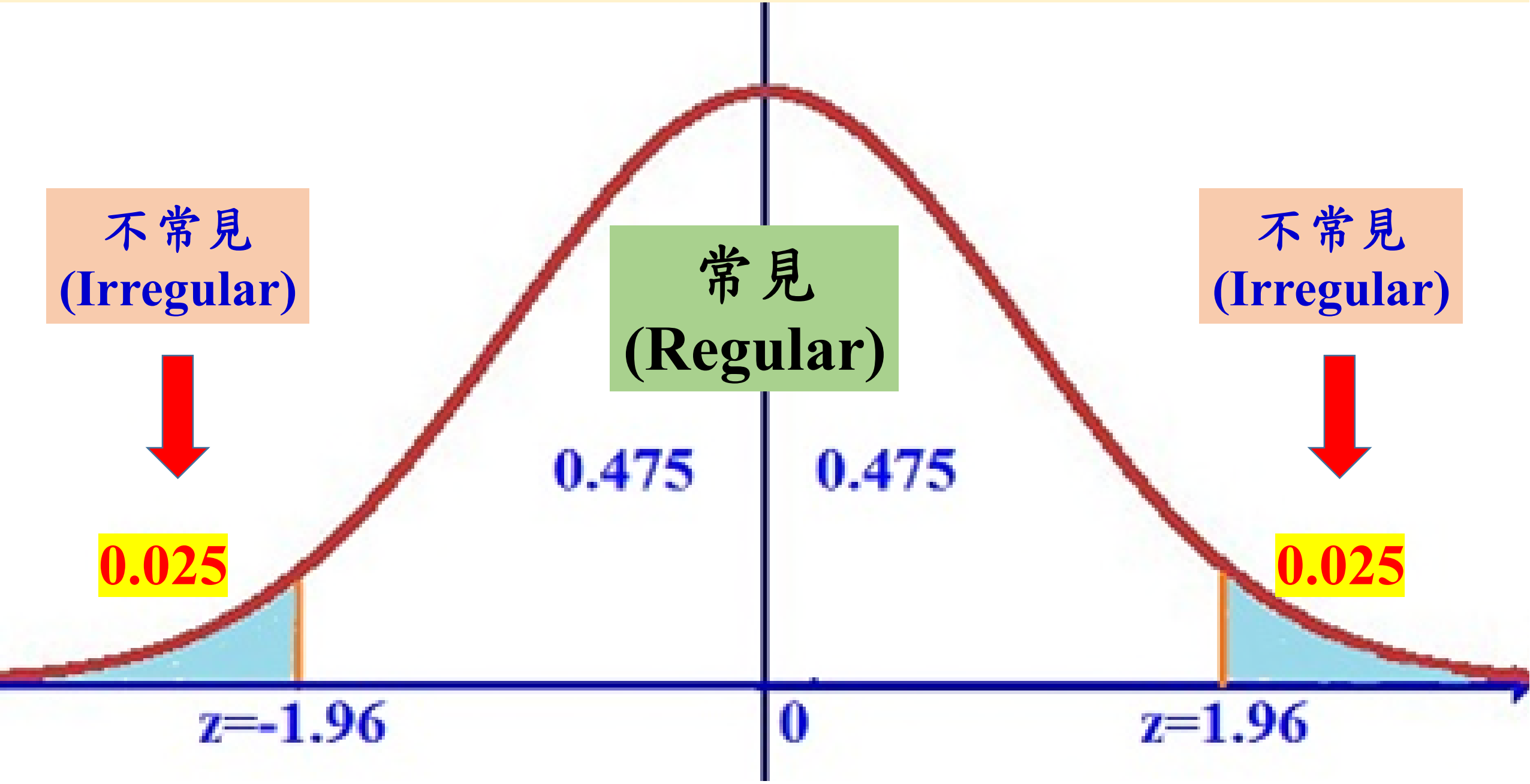

Lower-Tailed Test About a Population Mean: σ Known (1 of 2)

p-Value Approach

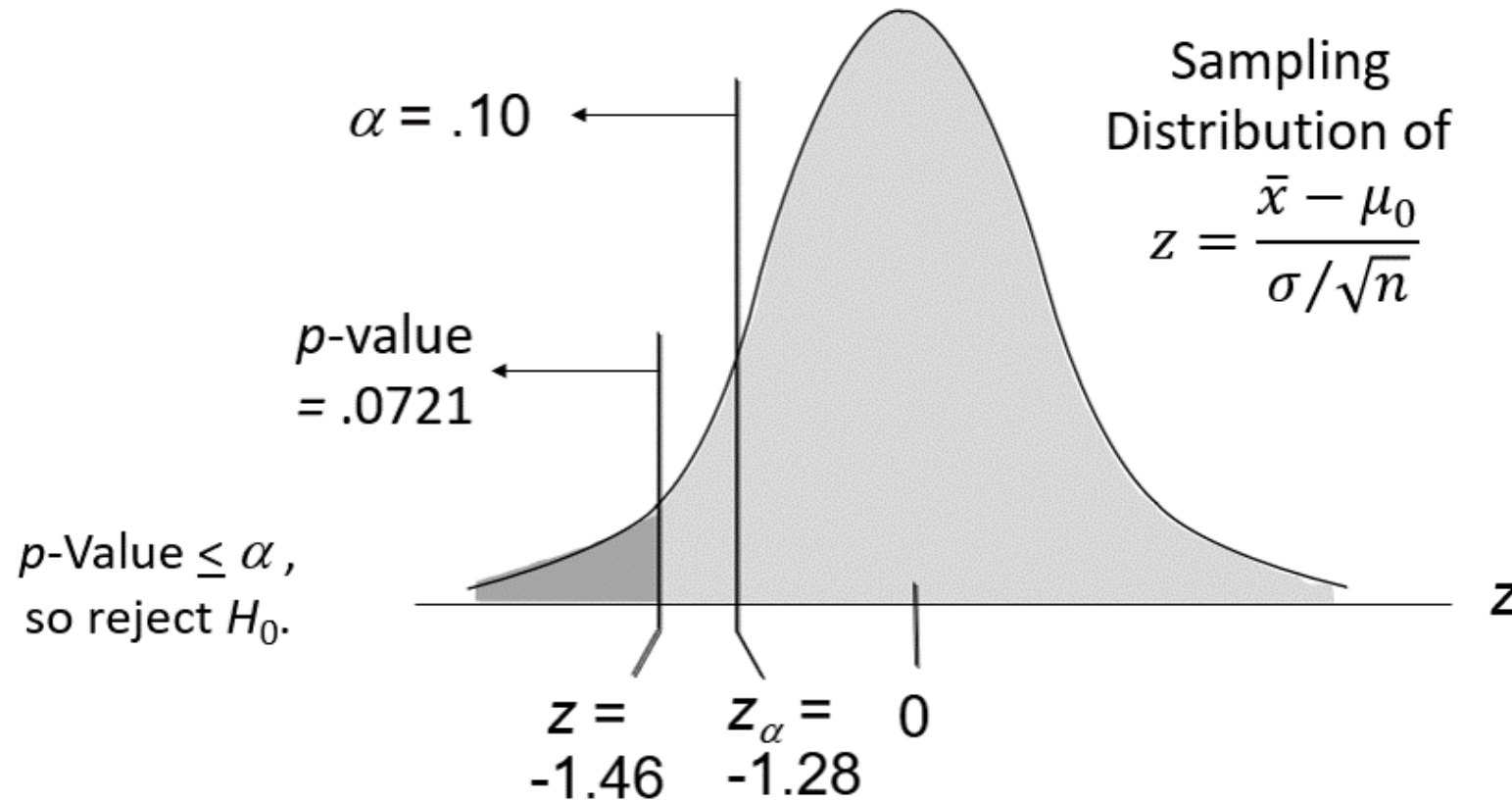

Lower-Tailed Test About a Population Mean: σ Known (2 of 2)

Critical Value Approach (臨界值)

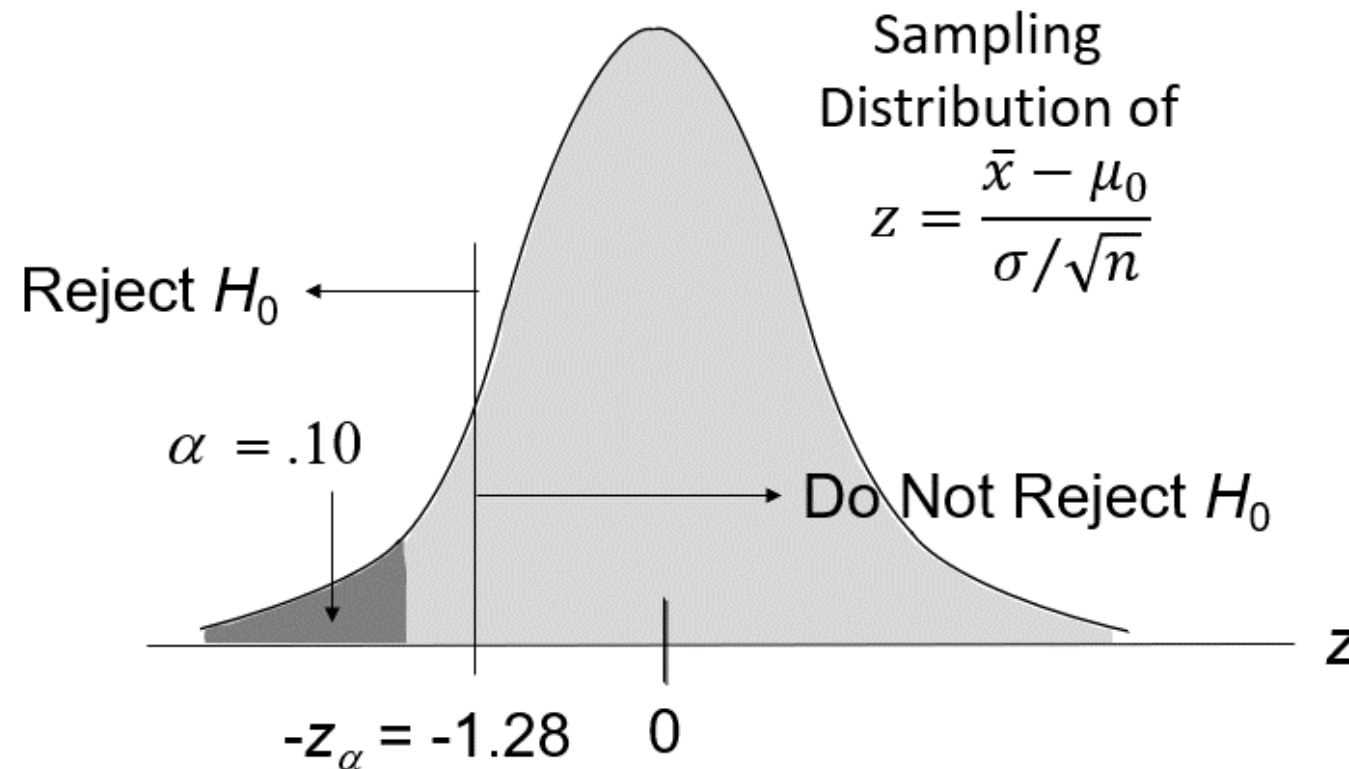

Steps of Hypothesis Testing

Step 1. Develop the null and alternative hypotheses.

Step 2. Specify the level of significance α .

Step 3. Collect the sample data and compute the value of the test statistic.

p -Value Approach

Step 4. Use the value of the test statistic to compute the p -value.

Step 5. Reject H_0 if $p\text{-value} \leq \alpha$.

Critical Value Approach

Step 4. Use the level of significance α to determine the critical value and the rejection rule.

Step 5. Use the value of the test statistic and the rejection rule to determine whether to reject H_0 .

One-Tailed Test About a Population Mean: σ Unknown (1 of 4)

1. Develop the hypotheses.

$$H_0: \mu \leq 65$$

$$H_a: \mu > 65$$

2. Specify the level of significance. $\alpha = .05$

3. Compute the value of the test statistic.

$$t = \frac{\bar{x} - \mu_0}{s/\sqrt{n}} = \frac{66.2 - 65}{4.2/\sqrt{64}} = 2.286$$

One-Tailed Test About a Population Mean: σ Unknown (2 of 4)

p –Value Approach

4. Compute the p –value.

For $t = 2.286$, the p -value must be greater than 0.01 (for $t = 2.387$), but less than 0.025 (for $t = 1.998$).

$$0.01 < p\text{-value} < 0.025$$

5. Determine whether to reject H_0 .

Because $p\text{-value} < \alpha = 0.05$, we reject H_0 .

We are at least 95% confident that the mean speed of vehicles at Location F is greater than 65 km/h.

One-Tailed Test About a Population Mean: σ Unknown (3 of 4)

Critical Value Approach

4. Determine the critical value and the rejection rule.

For $\alpha = 0.05$ and $df = 64 - 1 = 63$, $t_{0.05} = 1.669$.

We will reject H_0 if $t \geq 1.669$.

5. Determine whether to reject H_0 .

Because $2.286 \geq 1.669$, we reject H_0 .

We are at least 95% confident that the mean speed of vehicles at Location F is greater than 65 km/h. Location F is a good candidate for a radar trap.

One-Tailed Test About a Population Mean: σ Unknown (4 of 4)

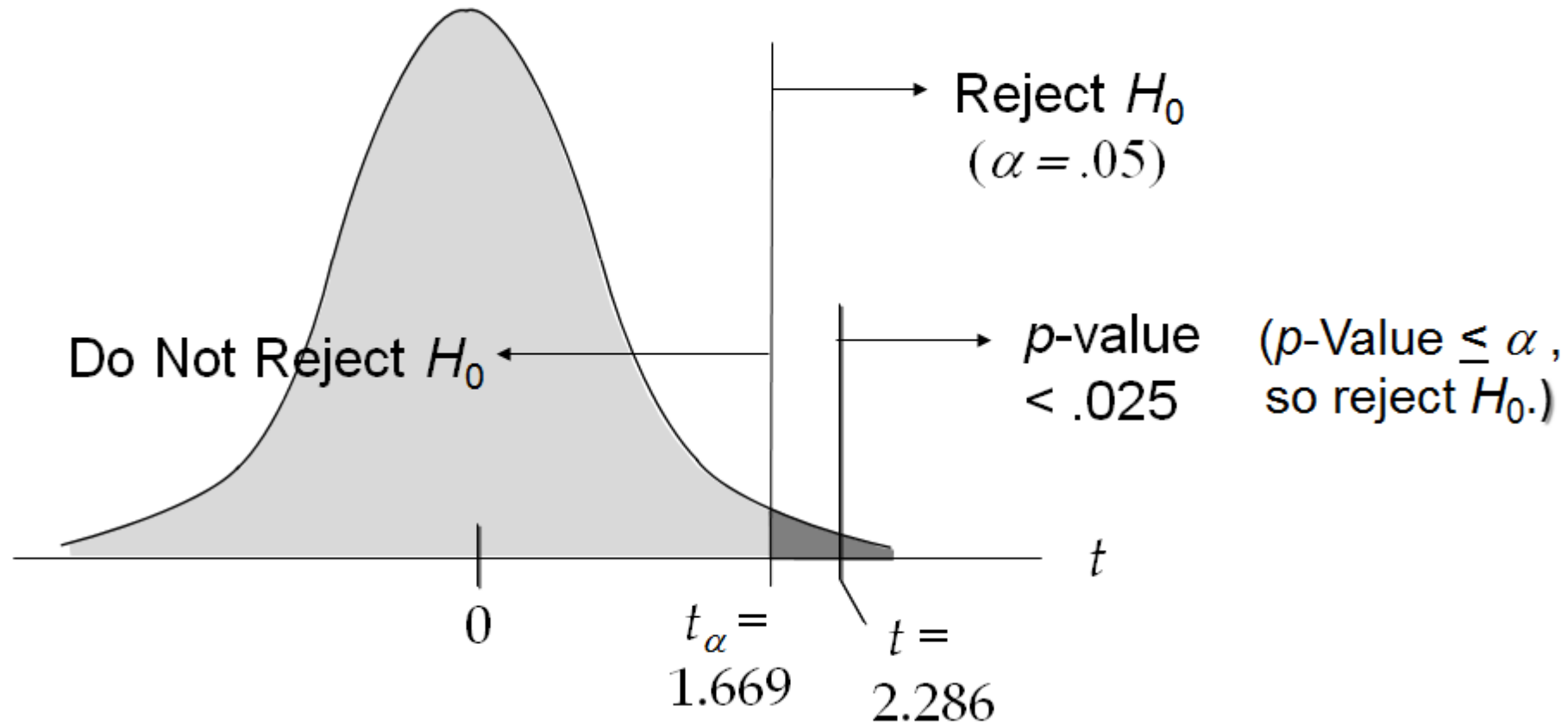

A Summary of Forms for Null and Alternative Hypotheses About a Population Proportion

- The equality part of the hypotheses always appears in the null hypothesis.
- In general, a hypothesis test about the value of a population proportion p must take one of the following three forms (where p_0 is the hypothesized value of the population proportion).

1. One-tailed, lower tail: $H_0: p \geq p_0$ $H_a: p < p_0$

2. One-tailed, upper tail: $H_0: p \leq p_0$ $H_a: p > p_0$

3. Two-tailed: $H_0: p = p_0$ $H_a: p \neq p_0$

Tests About a Population Proportion (1 of 2)

Test Statistic:

$$z = \frac{\bar{p} - p_0}{\sqrt{\frac{p_0(1 - p_0)}{n}}}$$

Assuming $np \geq 5$ and $n(1 - p) \geq 5$.

Tests About a Population Proportion (2 of 2)

- Rejection Rule: p –Value Approach

Reject H_0 if p –value $\leq \alpha$

- Rejection Rule: Critical Value Approach

- Lower-tail: Reject H_0 if $z \leq -z_\alpha$
- Upper-tail: Reject H_0 if $z \geq z_\alpha$
- Two-tail: Reject H_0 if $z \leq -z_\alpha$ or if $z \geq z_\alpha$

Two-Tailed Test About a Population Proportion (1 of 4)

Example: National Safety Council (NSC)

For a Christmas and New Year's week, the National Safety Council estimated that 500 people would be killed and 25,000 injured on the nation's roads. The NSC claimed that 50% of the accidents would be caused by drunk driving.

A sample of 120 accidents showed that 67 were caused by drunk driving. Use these data to test the NSC's claim with $\alpha = 0.05$.

Two-Tailed Test About a Population Proportion (2 of 4)

1. Determine the hypotheses. $H_0: p = .5$ and $H_a: p \neq .5$
2. Specify the level of significance. $\alpha = .05$
3. Compute the value of the test statistic.

$$\sigma_{\bar{p}} = \sqrt{\frac{p_0(1-p_0)}{n}} = \sqrt{\frac{.5(1-.5)}{120}} = .045644$$

$$Z = \frac{\bar{p} - p_0}{\sigma_{\bar{p}}} = \frac{\left(\frac{67}{120}\right) - .5}{.045644} = 1.28$$

Two-Tailed Test About a Population Proportion (3 of 4)

p -Value Approach

4. Compute the p -value.

For $z = 1.28$, the cumulative probability = 0.8997.

$$p\text{-value} = 2(1 - 0.8997) = \mathbf{0.2006}.$$

5. Determine whether to reject H_0 .

Because $p\text{-value} = 0.2006 > \alpha = 0.05$, we cannot reject H_0 .

We do not have convincing evidence that the true proportion of accidents that would be caused by drunk driving is different than 50%.

Two-Tailed Test About a Population Proportion (4 of 4)

Critical Value Approach

4. Determine the critical value and the rejection rule.

For $\alpha/2 = 0.05/2 = 0.025$, $z_{0.025} = 1.96$.

We will reject H_0 if $z \leq -1.96$ or if $z \geq 1.96$.

5. Determine whether to reject H_0 .

Because 1.278 is not less than -1.96 and is not greater than 1.96, we cannot reject H_0 .

We do not have convincing evidence that the true proportion of accidents that would be caused by drunk driving is different than 50%.

Chapter 10 - Inference About Means and Proportions with Two Populations

10.1 – Inferences about the Difference Between Two Population Means: σ_1 and σ_2 Known

10.2 – Inferences about the Difference Between Two Population Means: σ_1 and σ_2 Unknown

10.3 – Inferences about the Difference Between Two Population Means: Matched Samples

10.4 – Inferences about the Difference Between Two Population Proportions

Estimating the Difference Between Two Population Means (1 of 2)

- μ_1 = the mean of population 1 and μ_2 = the mean of population 2.
- The difference between the two population means is $\mu_1 - \mu_2$.

To estimate $\mu_1 - \mu_2$, we will select a simple random sample of size n_1 from population 1 and a simple random sample of size n_2 from population 2.

- \bar{x}_1 = the mean of sample 1 and \bar{x}_2 = the mean of sample 2.
- The point estimator of the difference between the means of the populations 1 and 2 is $\bar{x}_1 - \bar{x}_2$.

Sampling Distribution of $\bar{x}_1 - \bar{x}_2$

- Mean/Expected value:

$$E(\bar{x}_1 - \bar{x}_2) = \mu_1 - \mu_2$$

- Standard Deviation (Standard Error):

$$\sigma_{\bar{x}_1 - \bar{x}_2} = \sqrt{\frac{(\sigma_1)^2}{n_1} + \frac{(\sigma_2)^2}{n_2}}$$

Where: σ_1 = standard deviation of population 1

σ_2 = standard deviation of population 2

n_1 = sample size from population 1

n_2 = sample size from population 2

Interval Estimation of $\mu_1 - \mu_2$ when σ_1 and σ_2 are Known (1 of 3)

Interval Estimate

$$(\bar{x}_1 - \bar{x}_2) \pm z_{\alpha/2} \sqrt{\frac{(\sigma_1)^2}{n_1} + \frac{(\sigma_2)^2}{n_2}}$$

Where $1 - \alpha$ is the confidence coefficient.

Interval Estimation of $\mu_1 - \mu_2$ when σ_1 and σ_2 are Known (2 of 3)

Example: Par, Inc.

Par, Inc. is a manufacturer of golf equipment and has developed a new golf ball that has been designed to provide “extra distance.”

In a test of driving distance using a mechanical driving device, a sample of Par golf balls was compared with a sample of golf balls made by Rap, Ltd., a competitor. The sample statistics appear on the next slide.

Interval Estimation of $\mu_1 - \mu_2$ when σ_1 and σ_2 are Known (3 of 3)

Example: Par, Inc.

	Sample # 1 Par, Inc.	Sample # 2 Rap, Ltd.
Sample Size	120 balls	80 balls
Sample Mean	295 yards	278 yards

Based on data from previous driving distance tests, the two population standard deviations are known with $\sigma_1 = 15$ yards and $\sigma_2 = 20$ yards.

Let us develop a 95% confidence interval estimate of the difference between the mean driving distances of the two brands of golf ball.

Estimating the Difference Between Two Population Means (2 of 2)

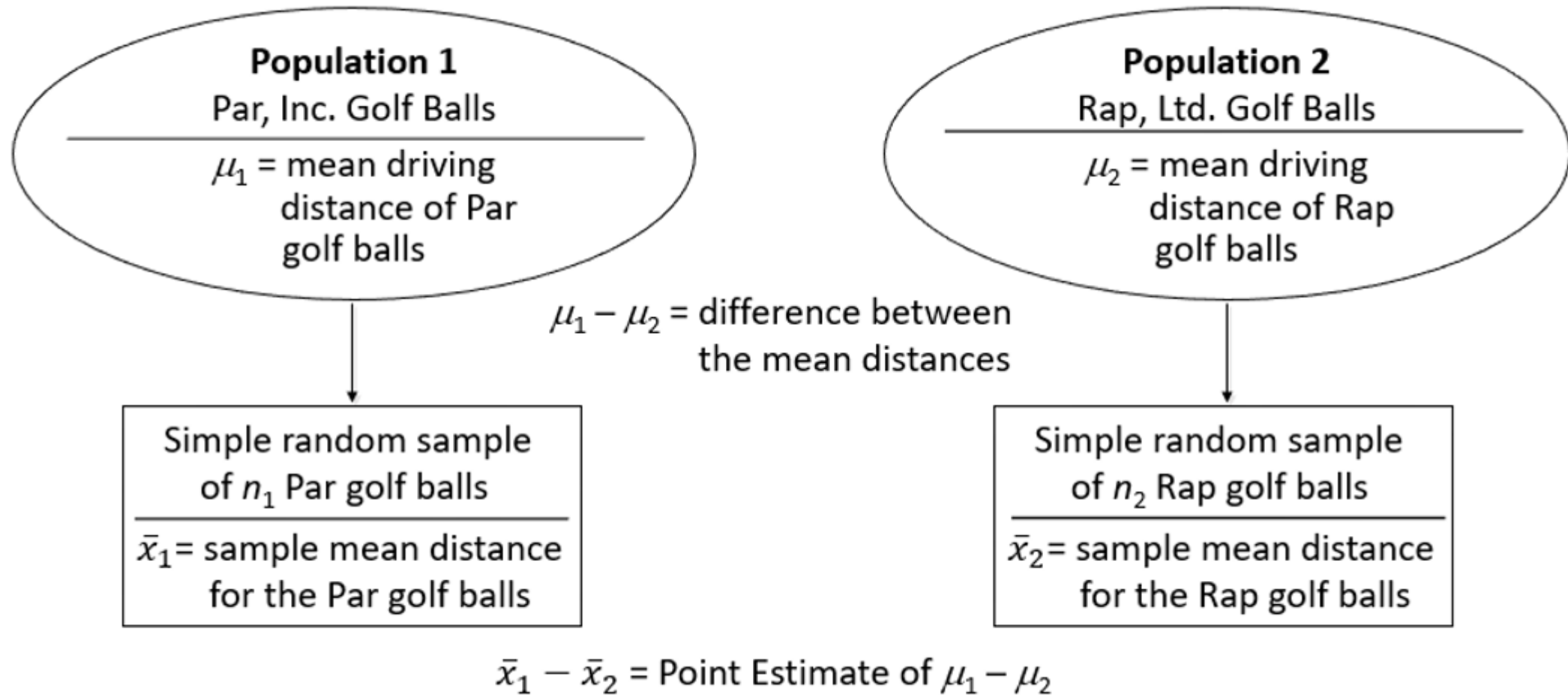

Interval Estimation of $\mu_1 - \mu_2$ when σ_1 and σ_2 are Known

$$(\bar{x}_1 - \bar{x}_2) \pm z_{\alpha/2} \sqrt{\frac{(\sigma_1)^2}{n_1} + \frac{(\sigma_2)^2}{n_2}}$$

$$(295 - 278) \pm 1.96 \sqrt{\frac{(15)^2}{120} + \frac{(20)^2}{80}}$$

$$17 \pm 5.14$$

$$11.86 \text{ to } 22.14$$

We are 95% confident that the difference between the mean driving distances of Par, Inc. balls and Rap, Ltd. balls is 11.86 to 22.14 yards.

Hypothesis Tests About $\mu_1 - \mu_2$ when σ_1 and σ_2 are Known (1 of 5)

A hypothesis test about the value of the difference in two population means $\mu_1 - \mu_2$ must take one of the following three forms (where D_0 is the hypothesized difference in the population means)

1. One-tailed, lower tail: $H_0: \mu_1 - \mu_2 \geq D_0$ $H_a: \mu_1 - \mu_2 < D_0$

2. One-tailed, upper tail: $H_0: \mu_1 - \mu_2 \leq D_0$ $H_a: \mu_1 - \mu_2 > D_0$

3. Two-tailed: $H_0: \mu_1 - \mu_2 = D_0$ $H_a: \mu_1 - \mu_2 \neq D_0$

Test Statistic:
$$Z = \frac{(\bar{x}_1 - \bar{x}_2) - D_0}{\sqrt{\frac{(\sigma_1)^2}{n_1} + \frac{(\sigma_2)^2}{n_2}}}$$

Hypothesis Tests About $\mu_1 - \mu_2$ when σ_1 and σ_2 are Known (2 of 5)

Example: Par, Inc.

Can we conclude, using $\alpha = 0.01$, that the mean driving distance of Par, Inc. golf balls is greater than the mean driving distance of Rap, Ltd. golf balls?

Hypothesis Tests About $\mu_1 - \mu_2$ when σ_1 and σ_2 are Known (3 of 5)

1. Develop the hypotheses. $H_0: \mu_1 - \mu_2 \leq 0$

$$H_a: \mu_1 - \mu_2 > 0$$

μ_1 = the mean distance for the population of Par, Inc. golf balls

μ_2 = the mean distance for the population of Rap, Ltd. golf balls

2. Specify the level of significance. $\alpha = 0.01$

3. Compute the value of the test statistic.

$$Z = \frac{(\bar{x}_1 - \bar{x}_2) - D_0}{\sqrt{\frac{(\sigma_1)^2}{n_1} + \frac{(\sigma_2)^2}{n_2}}} = \frac{(295 - 278) - 0}{\sqrt{\frac{(15)^2}{120} + \frac{(20)^2}{80}}} = \frac{17}{2.62} = \mathbf{6.49}$$

Hypothesis Tests About $\mu_1 - \mu_2$ when σ_1 and σ_2 are Known (4 of 5)

p -Value Approach

4. Compute the p -value.

For $z = 6.49$, the p -value **< 0.0001**

5. Determine whether to reject H_0 .

Because p -value $< 0.0001 \leq \alpha = 0.01$, we reject H_0 .

At the 0.01 level of significance, the sample evidence indicates the mean driving distance of Par, Inc. golf balls is greater than the mean driving distance of Rap, Ltd. golf balls.

Hypothesis Tests About $\mu_1 - \mu_2$ when σ_1 and σ_2 are Known (5 of 5)

Critical Value Approach

4. Determine the critical value and the rejection rule.

For $\alpha = 0.01$, $z_{0.01} = 2.33$. We will reject H_0 if $z \geq 2.33$.

5. Determine whether to reject H_0 .

Because $6.49 \geq 2.33$, we reject H_0 .

The sample evidence indicates the mean driving distance of Par, Inc. golf balls is greater than the mean driving distance of Rap, Ltd. golf balls.

Interval Estimation of $\mu_1 - \mu_2$ when σ_1 and σ_2 are Unknown (1 of 6)

When σ_1 and σ_2 are unknown we will:

1. Use the sample standard deviations, s_1 and s_2 , as estimates of σ_1 and σ_2 and
2. Replace $z_{\alpha/2}$ with $t_{\alpha/2}$.

Interval Estimation of $\mu_1 - \mu_2$ when σ_1 and σ_2 are Unknown (2 of 6)

Interval Estimate

$$(\bar{x}_1 - \bar{x}_2) \pm t_{\alpha/2} \sqrt{\frac{(s_1)^2}{n_1} + \frac{(s_2)^2}{n_2}}$$

Where the degrees of freedom for $t_{\alpha/2}$ are:

$$df = \frac{\left(\frac{(s_1)^2}{n_1} + \frac{(s_2)^2}{n_2}\right)^2}{\left(\frac{1}{n_1 - 1}\right) \left(\frac{(s_1)^2}{n_1}\right)^2 + \left(\frac{1}{n_2 - 1}\right) \left(\frac{(s_2)^2}{n_2}\right)^2}$$

Interval Estimation of $\mu_1 - \mu_2$ when σ_1 and σ_2 are Unknown (3 of 6)

Example: Specific Motors

Specific Motors of Detroit has developed a new Automobile known as the M car. 24 M cars and 28 J cars (from Japan) were road tested to compare miles-per-gallon (mpg) performance.

	Sample #1 M Cars	Sample #2 J Cars
Sample Size	24 cars	28 cars
Sample Mean	29.8 miles per gallon	27.3 miles per gallon
Sample Std. Dev.	2.56 miles per gallon	1.81 miles per gallon

Interval Estimation of $\mu_1 - \mu_2$ when σ_1 and σ_2 are Unknown (4 of 6)

Let us develop a 90% confidence interval estimate of the difference between the mpg performances of the two models of automobile.

Let

μ_1 = the mean miles per gallon for the population of M cars.

μ_2 = the mean miles per gallon for the population of J cars.

Interval Estimation of $\mu_1 - \mu_2$ when σ_1 and σ_2 are Unknown (5 of 6)

The degrees of freedom for $t_{\alpha/2}$ are

$$df = \frac{\left(\frac{(2.56)^2}{24} + \frac{(1.81)^2}{28} \right)^2}{\left(\frac{1}{24-1} \right) \left(\frac{(2.56)^2}{24} \right)^2 + \left(\frac{1}{28-1} \right) \left(\frac{(1.81)^2}{28} \right)^2} = 40.59 = \mathbf{41}$$

With $\alpha/2 = 0.05$ and $df = 41$, $t_{\alpha/2} = 1.683$

Interval Estimation of $\mu_1 - \mu_2$ when σ_1 and σ_2 are Unknown (6 of 6)

$$(\bar{x}_1 - \bar{x}_2) \pm t_{\alpha/2} \sqrt{\frac{(s_1)^2}{n_1} + \frac{(s_2)^2}{n_2}}$$

$$(29.8 - 27.3) \pm 1.683 \sqrt{\frac{(2.56)^2}{24} + \frac{(1.81)^2}{28}}$$

$$2.5 \pm 1.051$$

1.449 to 3.551 mpg

We are 90% confident that the difference between the miles-per-gallon performances of M cars and J cars is 1.449 to 3.551 mpg.

Hypothesis Tests About $\mu_1 - \mu_2$ when σ_1 and σ_2 are Unknown (1 of 6)

A hypothesis test about the value of the difference in two population means $\mu_1 - \mu_2$ must take one of the following three forms (where D_0 is the hypothesized difference in the population means)

- | | | |
|----------------------------|-------------------------------|-------------------------------|
| 1. One-tailed, lower tail: | $H_0: \mu_1 - \mu_2 \geq D_0$ | $H_a: \mu_1 - \mu_2 < D_0$ |
| 2. One-tailed, upper tail: | $H_0: \mu_1 - \mu_2 \leq D_0$ | $H_a: \mu_1 - \mu_2 > D_0$ |
| 3. Two-tailed: | $H_0: \mu_1 - \mu_2 = D_0$ | $H_a: \mu_1 - \mu_2 \neq D_0$ |

Test Statistic:

$$t = \frac{(\bar{x}_1 - \bar{x}_2) - D_0}{\sqrt{\frac{(s_1)^2}{n_1} + \frac{(s_2)^2}{n_2}}}$$

Hypothesis Tests About $\mu_1 - \mu_2$ when σ_1 and σ_2 are Unknown (2 of 6)

Example: Specific Motors

Can we conclude, using a .05 level of significance, that the miles-per-gallon (*mpg*) performance of M cars is greater than the miles-per-gallon performance of J cars?

Hypothesis Tests About $\mu_1 - \mu_2$ when σ_1 and σ_2 are Unknown (3 of 6)

1. Develop the hypotheses. $H_0: \mu_1 - \mu_2 \leq 0$

$$H_a: \mu_1 - \mu_2 > 0$$

μ_1 = the mean mpg for the population of M cars

μ_2 = the mean mpg for the population of J cars

2. Specify the level of significance. $\alpha = 0.05$

3. Compute the value of the test statistic

$$t = \frac{(\bar{x}_1 - \bar{x}_2) - D_0}{\sqrt{\frac{(s_1)^2}{n_1} + \frac{(s_2)^2}{n_2}}} = \frac{(29.8 - 27.3) - 0}{\sqrt{\frac{(2.56)^2}{24} + \frac{(1.81)^2}{28}}} = \mathbf{4.003}$$

Hypothesis Tests About $\mu_1 - \mu_2$ when σ_1 and σ_2 are Unknown (4 of 6)

The Degrees of freedom for t, are

$$df = \frac{\left[\frac{(2.56)^2}{24} + \frac{(1.81)^2}{28} \right]^2}{\frac{1}{24-1} \left[\frac{(2.56)^2}{24} \right]^2 + \frac{1}{28-1} \left[\frac{(1.81)^2}{28} \right]^2} = 40.59 = 41$$

Hypothesis Tests About $\mu_1 - \mu_2$ when σ_1 and σ_2 are Unknown (5 of 6)

p -Value Approach

4. Compute the p -value.

For $t = 4.003$ and $df = 41$, the p -value $< \mathbf{0.005}$

5. Determine whether to reject H_0 .

Because p -value $\leq \alpha = 0.05$, we reject H_0 .

At the 0.05 level of significance, the sample evidence indicates that the miles-per-gallon (*mpg*) performance of M cars is greater than the miles-per-gallon performance of J cars.

Hypothesis Tests About $\mu_1 - \mu_2$ when σ_1 and σ_2 are Unknown (6 of 6)

Critical Value Approach

- Determine the critical value and the rejection rule.

For $\alpha = 0.05$ and $df = 41$, $t_{0.05} = 1.683$. We will reject H_0 if $t \geq 1.683$.

- Determine whether to reject H_0 .

Because $4.003 \geq 1.683$, we reject H_0 .

We are at least 95% confident that the miles-per-gallon (*mpg*) performance of M cars is greater than the miles-per-gallon performance of J cars.

Inferences About the Difference Between Two Population Means: Matched Samples

- With a matched-sample design each sampled item provides a pair of data values.
- This design often leads to a smaller sampling error than the independent-sample design because variation between sampled items is eliminated as a source of sampling error.

Inferences About the Difference Between Two Population Means: Matched Samples

■ Example: Express Deliveries

A Chicago-based firm has documents that must be quickly distributed to district offices throughout the U.S. The firm must decide between two delivery services, UPX (United Parcel Express) and INTEX (International Express), to transport its documents.



Inferences About the Difference Between Two Population Means: Matched Samples

■ Example: Express Deliveries

In testing the delivery times of the two services, the firm sent two reports to a random sample of its district offices with one report carried by UPX and the other report carried by INTEX. Do the data on the next slide indicate a difference in mean delivery times for the two services? Use a .05 level of significance.



Delivery Time (Hours)

<u>District Office</u>	<u>UPX</u>	<u>INTEX</u>	<u>Difference</u>
Seattle	32	25	7
Los Angeles	30	24	6
Boston	19	15	4
Cleveland	16	15	1
New York	15	13	2
Houston	18	15	3
Atlanta	14	15	-1
St. Louis	10	8	2
Milwaukee	7	9	-2
Denver	16	11	5



■ p –Value and Critical Value Approaches

1. Develop the hypotheses.

$$H_0: \mu_d = 0$$

$$H_a: \mu_d \neq 0$$

Let μ_d = the mean of the difference values for the two delivery services for the population of district offices



■ p –Value and Critical Value Approaches

2. Specify the level of significance. $\alpha = .05$

3. Compute the value of the test statistic.

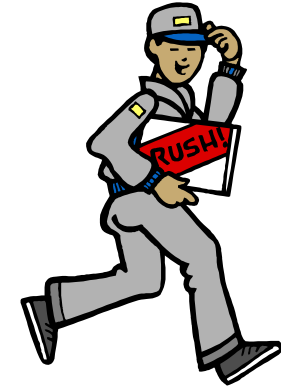

$$\bar{d} = \frac{\sum d_i}{n} = \frac{(7+6+\dots+5)}{10} = 2.7$$

$$s_d = \sqrt{\frac{\sum (d_i - \bar{d})^2}{n-1}} = \sqrt{\frac{76.1}{9}} = 2.9$$

$$t = \frac{\bar{d} - \mu_d}{s_d / \sqrt{n}} = \frac{2.7 - 0}{2.9 / \sqrt{10}} = 2.94$$

■ p –Value Approach

➤ 4. Compute the p –value.

For $t = 2.94$ and $df = 9$, the p –value is between .02 and .01. (This is a two-tailed test, so we double the upper-tail areas of .01 and .005.)

➤ 5. Determine whether to reject H_0 .

Because p –value $\leq \alpha = .05$, we reject H_0 .

We are at least 95% confident that there is a difference in mean delivery times for the two services?



■ Critical Value Approach

- ▶ 4. Determine the critical value and rejection rule.

For $\alpha = .05$ and $df = 9$, $t_{.025} = 2.262$.

Reject H_0 if $t \geq 2.262$

- ▶ 5. Determine whether to reject H_0 .

Because $t = 2.94 \geq 2.262$, we reject H_0 .

We are at least 95% confident that there is a difference in mean delivery times for the two services?

